

# DJ-X3

## Service Manual

### CONTENTS

#### SPECIFICATIONS

- 1) GENERAL ..... 2
- 2) RECEIVER ..... 2

#### CIRCUIT DESCRIPTION

- 1) Receiver ..... 3~6
- 2) M38224M6M(E:XA0862, T:XA0836) ..... 7
- 3) Terminal function of CPU ..... 8

#### SEMICONDUCTOR DATA

- 1) uPD3140GS-E1 (XA0312) ..... 9
- 2) TC4W53FU (XA0348) ..... 10
- 3) NJM2904V (XA0573) ..... 10
- 4) CXA1622M/P (XA0787) ..... 10
- 5) MB88347LPFV-G-BND-EF (XA0599) ..... 11
- 6) TK11816M (XA0665) ..... 12
- 7) TK10931V (XA0666) ..... 12
- 8) TA4101FTE12L (XA0667) ..... 13
- 9) S-80828ALNP-EAR-T2 (XA0834) ..... 13
- 10) BR24C64F-E2 (XA0669) ..... 14
- 11) S-81230SG-QB-X (XA0833) ..... 14
- 12) uPC2757T-E3 (XA0743) ..... 15

- 13) TC7SET08FU (XA0586) ..... 15
- 14) LA3335M (XA0786) ..... 16
- 15) NJM2107 (XA0850) ..... 17
- 16) Transistor, Diode and LED Outline Drawings ..... 17
- 17) LCD Connection ..... 18

#### EXPLODED VIEW

- 1) Front View ..... 19
- 2) Bottom View ..... 20

#### PARTS LIST

- MAIN Unit ..... 21~26
- SW Unit ..... 26
- Mechanical Parts ..... 26
- Packing ..... 26

#### ADJUSTMENT

- 1) How to enter the adjustment mode ..... 27
- 2) Adjustment ..... 27~29

#### PC BOARD VIEW ..... 30~31

#### SCHEMATIC DIAGRAM ..... 32

#### BLOCK DIAGRAM ..... 33

# SPECIFICATIONS

## 1) GENERAL

Receiving range	E : 0.1 ~ 1299.995 MHz T : 0.1 ~ 823.995 MHz 850.000 ~ 868.995 MHz 895.000 ~ 1299.995 MHz
Modulation mode	FM, WFM, AM
Ant. impedance	50Ω
Ant. terminal	SMA
Supply voltage	DC 3.6V ~ 6V (Internal battery) DC 4.5V ~ 16V (external regulated source)
Ground	Negative ground
Current consumption	reception : approx.75mA Battery save (1:4)approx.39mA
Temperature range	-10 ~ +60°C (+14 ~ +140 F°)
Frequency stability	±5ppm(-10 ~ +60°C)(+14 ~ +140F°)
Dimension	56(W) × 102(H) × 23(D)mm
Weight	Approx.145g

## 2) RECEIVER

System	Triple-conversion superheterodyne
First IF	248.45 MHz
Second IF	38.85 MHz
Third IF	450 kHz
Selectivity	AM/FM -6dB/12kHz or over , -60dB/30kHz or less WFM -6dB/150kHz or over
Sensitivity	FM/WFM 12dB SINAD, AM 10dB S/N
Typ.	AM : 0.5 ~ 1.62MHz 17dBu 10dB S/N 1.625MHz or over 5dBu 10dB S/N FM : 30 ~ 550MHz -3dBu 12dB SINAD 550MHz or over 0dBu 12dB SINAD WFM : 76 ~ 770MHz 13dBu 12dB SINAD
Audio output power	more than 220mW (8Ω)

# CIRCUIT DESCRIPTION

## 1) Receiver

### 1. RX Method: Triple Super Heterodyne Method

1st IF. : 248.45MHz  
2nd IF. : 38.85MHz  
3rd IF. : 450KHz

### 2. Front End

0.1 ~ 29.995MHz

The signal input from antenna is switched at band switch D19, passing through the low pass filter, it is amplified at RF amplifier Q15. Then the signal is added to the 1st mixer IC3 through the band switch D17.

30 ~ 136.995MHz

The signal input from antenna is switched at band switch D23, passing through the band pass filter, it is amplified at RF amplifier Q21. Then the signal is added to the 1st mixer IC3 through the band switch D22.

137 ~ 222.995MHz

The signal input from antenna is switched at band switch D27, passing through the band pass filter, it is amplified at RF amplifier Q23. Then the signal is added to the 1st mixer IC3 through the band switch D26.

223 ~ 367.995MHz

The signal input from antenna is switched at band switch D29, passing through the band pass filter, it is amplified at RF amplifier Q27. Then the signal is added to the 1st mixer IC3 through the band switch D28.

368 ~ 469.995MHz

The signal input from antenna is switched at band switch D32, passing through the band pass filter, it is amplified at RF amplifier Q32. Then the signal is added to the 1st mixer IC3 through the band switch D31.

470 ~ 129.995 MHz

The signal input from antenna is switched at band switch D37 and D45, passing through the band pass filter, it is amplified at RF amplifier Q38. Then the signal is added to the 1st mixer IC3 through the band switch D36.

### 3. Mixer

The 1st Mixer

The input signal and the 1st local signal is added or subtracted at mixer IC3, and SAW filter FL1 selects the signal of 248.45 MHz, then eliminates the adjacent signal.

## The 2nd Mixer

The input signal and the 2nd local signal is added or subtracted at mixer IC4, and switched to FM/AM receiving side or WFM receiving side at D24 or D25 .

### FM/AM

At FM/AM receiving side, the crystal filter XF1 selects the signal of 38.85 MHz. The signal is amplified at the 1st IF amplifier Q22 after the adjacent signal is eliminated.

### WFM

At WFM receiving side, the band pass filter selects the signal of 38.85 MHz. The signal is amplified at the 1st IF amplifier Q22 after the adjacent signal is eliminated.

## 4. IF

### FM/AM

The amplified signal at the 1st IF amplifier Q22 is supplied to pin 24 of IC6 for demodulation. The signal of 12.8 MHz from the IC 1 reference buffer output is multiplied by 3 at Q17, then mixed with the signal added to pin 1 of IC6 in the mixer circuit inside IC6 to be converted into the 2nd IF signal of 450 kHz. The converted 2nd IF signal is output from pin 3 of IC6.

### FM

The output signal from pin 3 of IC6 is input to pin 7 of IC6 after the adjacent signal is eliminated at the ceramic filter FL2. The 2nd IF signal input to pin 7 of IC6 is demodulated at the limiter amplifier and quadrature detection circuit inside IC. Then the signal is output from pin 12 of IC6 as an AF signal.

### AM

The output signal from pin 3 of IC6 is input to pin 5 of IC6 after the adjacent signal is eliminated at the ceramic filter FL2. The 2nd IF signal input to pin 5 of IC6 is output from pin 13 of IC6 as an AF signal after AM is detected inside IC. Also reverse AGC is added to the 1st IF amplifier Q22 by AGC amplifier Q25 and the gain is controlled to get the normal audio output even though the input signal is fluctuated.

### WFM

The output signal from pin 3 of IC6 is input to pin 7 of IC6. The 2nd IF signal input to pin 7 of IC6 is demodulated at the limiter amplifier and quadrature detection circuit inside IC, and output from pin 12 of IC6 as an AF signal.

## 5. Squelch

The AF signal is output from pin 12 of IC6 and input to pin 19 of IC6. The input signal is output from pin 21 of IC6 through the noise filter amplifier and rectifying circuit. The rectified signal is supplied to the A/D port of microcomputer IC1. Then the microcomputer IC1 judges the signal to control ON/OFF of audio output.

## 6. Audio

### FM/AM/WFM

The audio output signal for receiving FM/WFM and AM is switched at IC9. The output audio signal is input to pin 1 of IC13 of stereo multiplex demodulator through AF amplifier IC17. When the input audio signal doesn't have a pilot signal, each audio signal is output from pin 9 and pin 10 to pin 1 and pin 16 of the audio amplifier IC14 equipped with the electronic volume. After the volume is adjusted, the signal is output from pin 7 and pin 10 to drive the speaker, etc. When the input signal has a pilot signal, each audio signal is output; L side signal is output from pin 9, and R side signal is output from pin 10.

Then the signals are input to the audio amplifier IC 14 equipped with electronic volume; L side signal is input to pin 1 and R side signal is input to pin 16. After adjusting the volume the signals are output; the L side from pin 7 and the R side from pin 10 to drive the speaker, etc.

## 7. VCO

### The 1st Local

VCO for the 1st local consists of the Colpitts oscillator. D15, D16 and L4 determine the frequency, and the signal is oscillated at the transistor Q9. The oscillated signal is supplied to pin 2 of PLL-IC1 passing through the buffer amplifier Q11 and Q10.

### The 2nd Local

VCO for the 2nd local consists of the Colpitts oscillator. D20, D21 and L15 determine the frequency, and the signal is oscillated at the transistor Q19. The oscillated signal is supplied to pin 19 of PLL-IC1 passing through the buffer amplifier Q20.

## 8. PLL

PLL-IC1 is used to control the oscillating frequency of VCO. IC1 is controlled by the serial control signal sent from the microprocessor IC7. The reference frequency of 12.8 MHz is generated by oscillating the crystal oscillator X1 inside the circuit.

### The 1st Local

IC1 compares the frequency gained by dividing the signal added to pin 2 of IC1 by the control signal from IC7 with the frequency gained by dividing the reference frequency of 12.8 MHz inside IC1. When the phase difference is found as a result of phase comparison, the pulse signal is output from the charge pump output of pin 8 of IC1, then the signal is converted into the DC voltage at the active filter Q13 and Q14 and added to the cathode side of VCO

vari-cap D15 and D16 to make the phases equal. In result the stabilized oscillation can be done at the desired frequency.

#### The 2nd Local

IC1 compares the frequency gained by dividing the signal added to pin 19 of IC1 by the control signal from IC7 with the frequency gained by dividing the reference frequency of 12.8 MHz inside IC1. When the phase difference is found as a result of phase comparison, the pulse signal is output from the charge pump output of pin 13 of IC1, then the signal is converted into the DC voltage at the inside circuit for active filter and added to the cathode side of VCO vari-cap D20 and D21 to make the phases equal. In result the stabilized oscillation can be done at the desired frequency.

## 2) M38224M6M (E:XA0862, T:XA0836)

CPU

Terminal Connection  
(TOP VIEW)

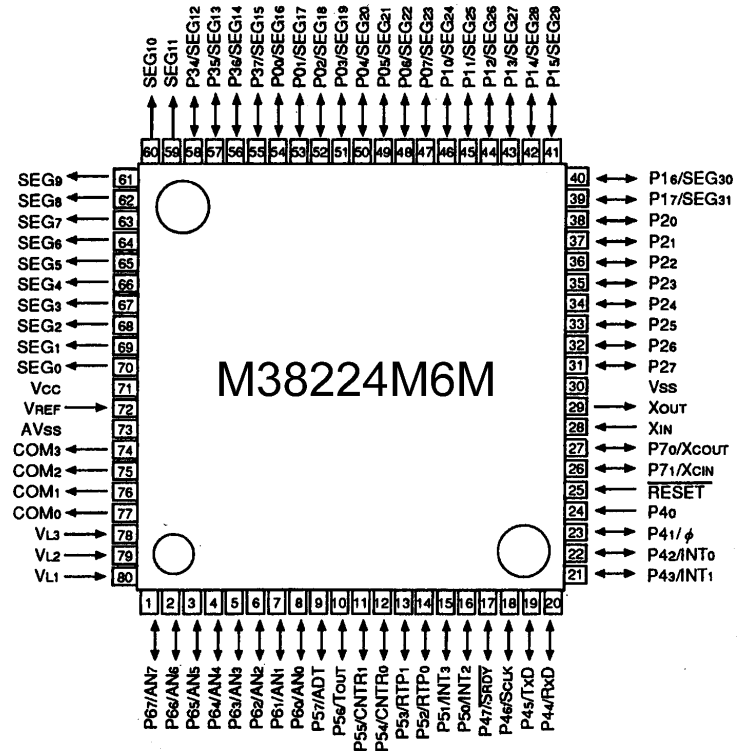

### 3) Terminal function of CPU

No.	Terminal	Signal	I/O	Description
1	AN7	BAT	AD	Battery input
2	P66	S/M	O	Stereo / Monophonic
3	P65	RESW	I	R/E push key
4	AN4	SQL	AD	Squelch input
5	AN3	SMT	AD	S-meter input
6	P62	AFPC	O	AF power supply
7	P61	BND3	O	Band3 SW
8	P60	BND6	O	Band6 SW
9	P57	BND2	O	Band2 SW
10	P56	BND4	O	Band4 SW
11	P55	BND5	O	Band5 SW
12	P54	BND1	O	Band1 SW
13	P53	ABAR	O	Antenna SW
14	P52	SBAR	O	Antenna SW
15	INT3	RE2	I	Rotary encoder input
16	P50	RE1	I	Rotary encoder input
17	P47	RC	O	RX SW
18	P46	ASW	O	Antenna SW
19	TXD	CTX	O	Clone TX
20	RXD	CRX	I	Clone RX
21	P43/INT1	PSW	I	Power key
22	INT0	BU	I	Backup interrupt
23	P41	BEEP	O	Beep output
24	P40	JKDT	I	Jack state input
25	RESET	RST	I	Reset interrupt
26	P71	SCK	O	EEPROM clock
27	P70	SDA	I/O	EEPROM data
28	XIN	XIN	I	Clock input
29	XOUT	XOUT	O	Clock output
30	VSS	VSS		GND
31	P27	SW2	I	Key input
32	P26	SW3	I	Key input
33	P25	SW4	I	Key input
34	P24	SW301	I	Key input
35	P23	SW302	I	Key input
36	P22	CLNSW	O	Clone SW
37	P21	STB2	O	DAC strobe
38	P20	DATA	I/O	Data / Unlock
39	SEG22	SEG22		
40	SEG21	SEG21		

No	Terminal	Signal	I/O	Description
41	SEG20	SEG20		
42	SEG19	SEG19		
43	SEG18	SEG18		
44	P12	DBC	O	Doubler SW
45	P11	C3C	O	Common power SW
46	P10	SCT	O	Secret signal output
47	P07	AFS	O	AF SW
48	P06	CLK	O	Clock
49	P05	STB1	O	PLL strobe
50	P04	PLL	O	PLL power supply
51	P03	P1C	O	PLL 1ch SW
52	P02	P2C	O	PLL 2ch SW
53	SEG17	SEG17		
54	SEG16	SEG16		
55	SEG15	SEG15		
56	SEG14	SEG14		
57	SEG13	SEG13		
58	SEG12	SEG12		
59	SEG11	SEG11		
60	SEG10	SEG10		
61	SEG9	SEG9		
62	SEG8	SEG8		
63	SEG7	SEG7		
64	SEG6	SEG6		
65	SEG5	SEG5		
66	SEG4	SEG4		
67	SEG3	SEG3		
68	SEG2	SEG2		
69	SEG1	SEG1		
70	SEG0	SEG0		
71	VCC	VDD		
72	VREF	VDD		
73	AVSS	GND		
74	COM3	COM3		
75	COM2	COM2		
76	COM1	COM1		
77	COM0	COM0		
78	VL3	VL3		
79	VL2	VL2		
80	VL1	VL1		



# SEMICONDUCTOR DATA

## 1) uPD3140GS-E1 (XA0312)

80 ~ 550MHz Dual PLL Synthesizer

### Specifications

Operating frequency: 200 ~ 400MHz ( $V_{in}=-12 \sim -0\text{dBm}$ , pin 2 and 19 input)  
 80 ~ 550MHz ( $V_{in}=-8 \sim -0\text{dBm}$ , pin 2 and 19 input)

Consumption current: 2.7 ~ 4.1mA ( $V_{cc}=1.8\text{V}$  while 1 channel is used)  
 4.3 ~ 6.6mA ( $V_{cc}=1.8\text{V}$  while both channels are used)  
 0 ~ 10uA ( $V_{cc}=1.8\text{V}$  in power save mode)  
 3.5 ~ 5.3mA ( $V_{cc}=5\text{V}$  while 1 channel is used)  
 5.6 ~ 8.6mA ( $V_{cc}=5\text{V}$  while both channels are used)

Operating voltage: 1.8 ~ 5.5V

### Block Diagram

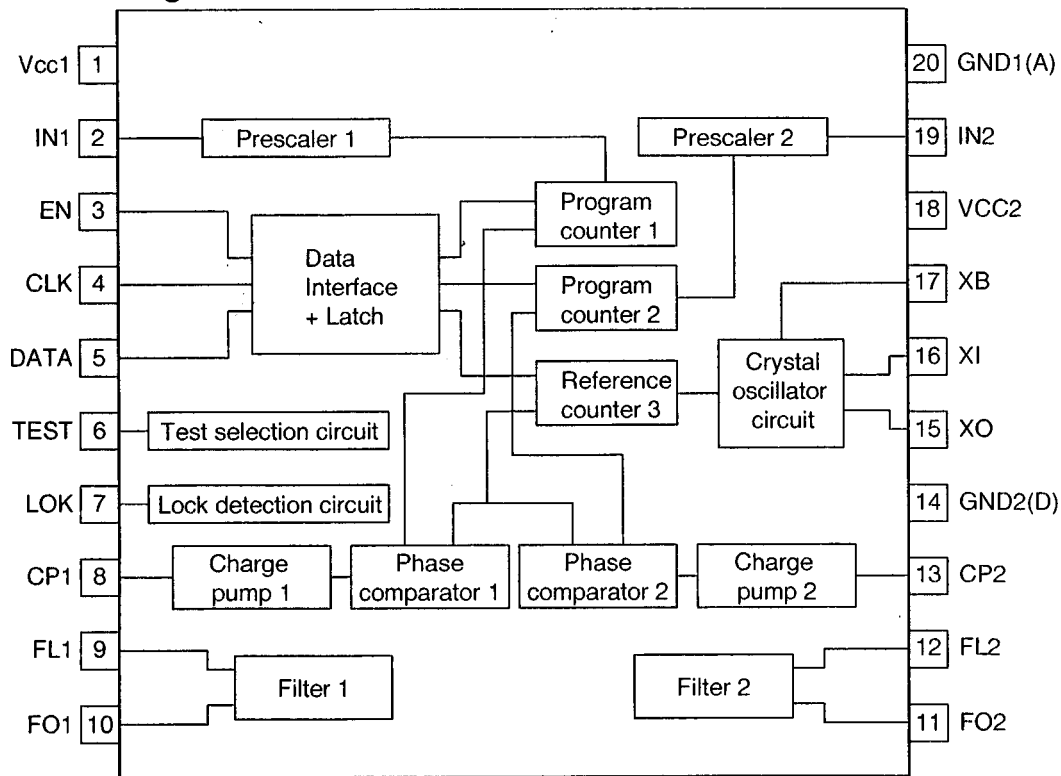

### Terminal Connection

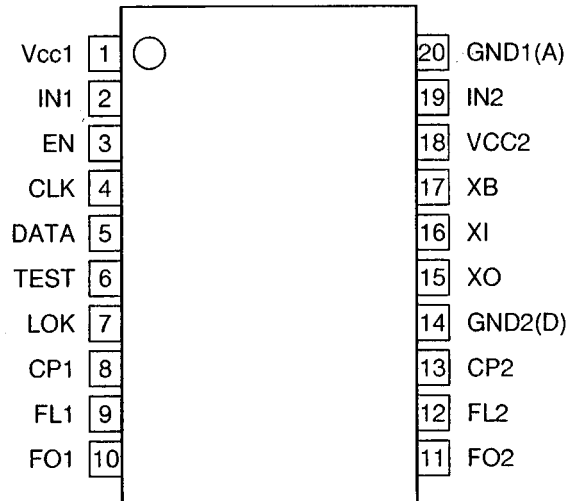

## 2) TC4W53FU (XA0348)

Pin Assignment

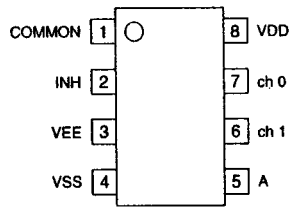

Block Diagram

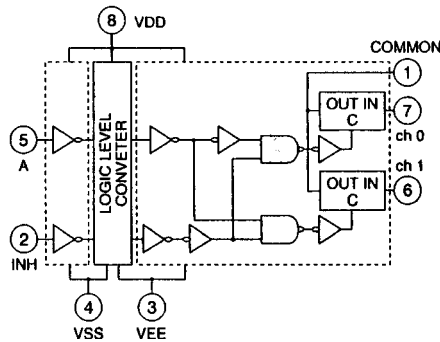

## 3) NJM2904V (XA0573)

Dual Single Supply Operational Amplifier

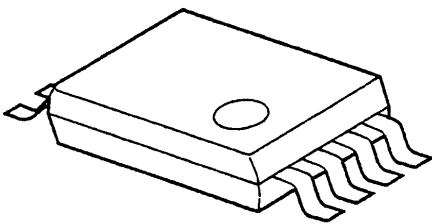

(Top View)

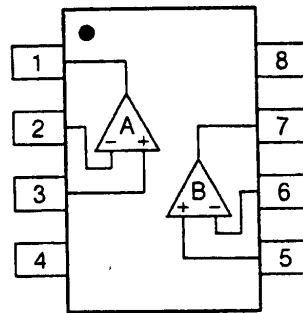

- 1: A OUTPUT
- 2: A - INPUT
- 3: A + INPUT
- 4: GND
- 5: B + INPUT
- 6: B - INPUT
- 7: B OUTPUT
- 8: V+

## 4) CXA1622M/P (XA0787)

Pin Assignment

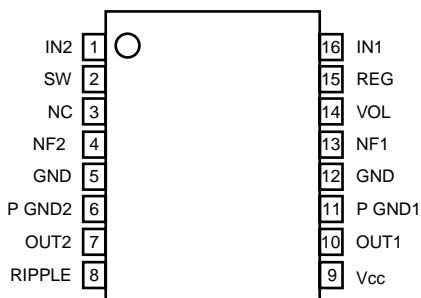

Block Diagram

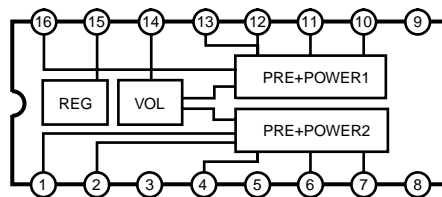

## 5) MB88347LPFV-G-BND-EF (XA0599)

D/A converter for digital tuning

### Block Diagram

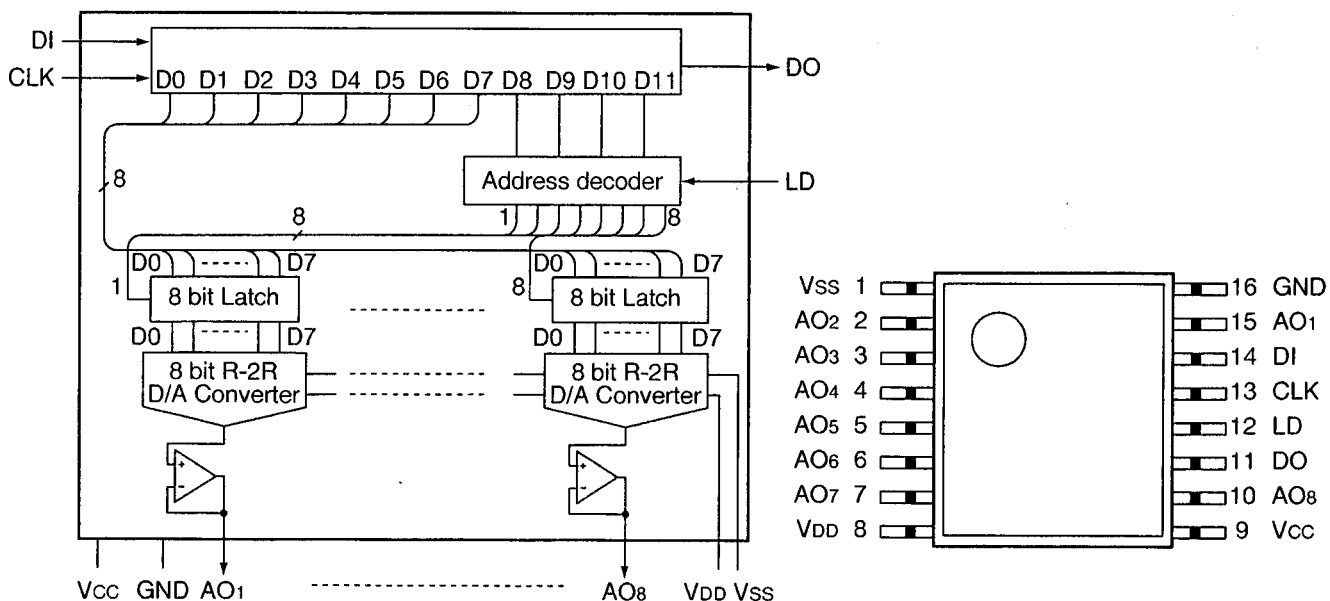

Pin No.	Name	I/O	Descriptions
14	DI	I	Serial data input terminal. Input 12 bit serial data. (Do not leave it open.)
11	DO	O	The MSB bit data of 12 bit shift register is output at the falling edge of CLK.
13	CLK	I	Shift clock input terminal. The input signal of DI terminal is input to 12 bit shift register at the rising edge of clock shift. (Do not leave it open.)
12	LD	I	When LD terminal is "High", the value of shift register is loaded in decoder and D/A output register. (Do not leave it open. Fix to "Low" when no data is transited.)
15 2 3 4 5 6 7 10	AO <sub>1</sub> AO <sub>2</sub> AO <sub>3</sub> AO <sub>4</sub> AO <sub>5</sub> AO <sub>6</sub> AO <sub>7</sub> AO <sub>8</sub>	O	8 bit D/A converter output terminal with operational amplifier.
9	V <sub>CC</sub>	-	MCU interface, power supply terminal of operational amplifier.
16	GND	-	MCU interface, ground terminal of operational amplifier.
8	V <sub>DD</sub>	-	Reference power supply (High) input terminal of D/A converter.
1	V <sub>SS</sub>	-	Reference power supply (Low) input terminal of D/A converter.

## 6) TK11816M (XA0665)

Pin Assignment

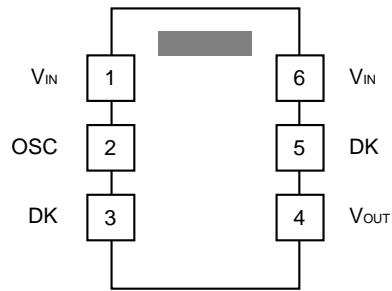

Block Diagram

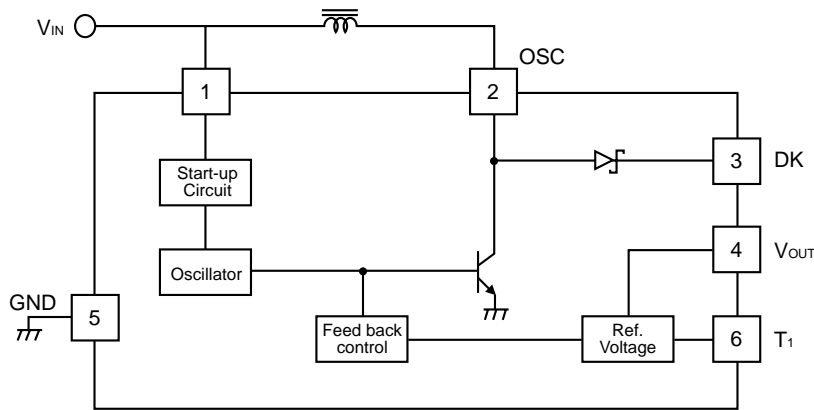

## 7) TK10931V (XA0666)

Pin Assignment / BLOCK Diagram (Top View)

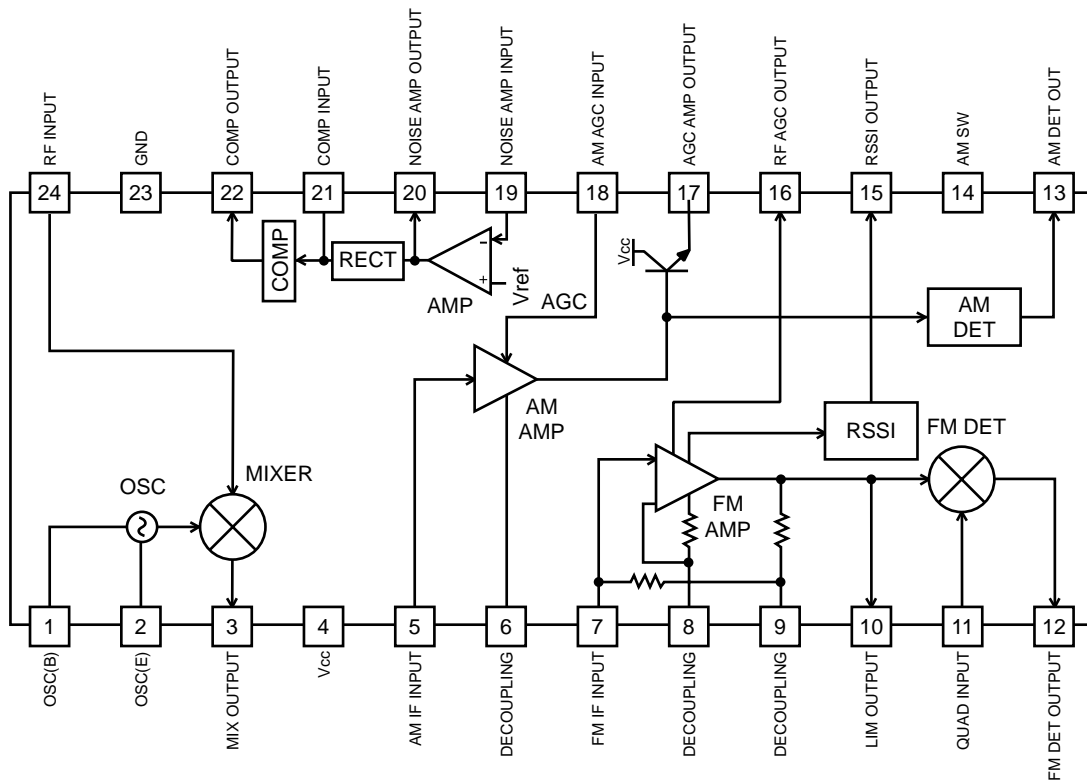

### 8) TA4101F TE12L (XA0667)

Pin Assignment

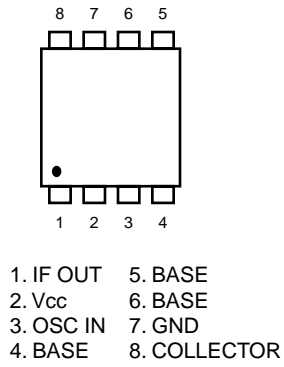

Block Diagram

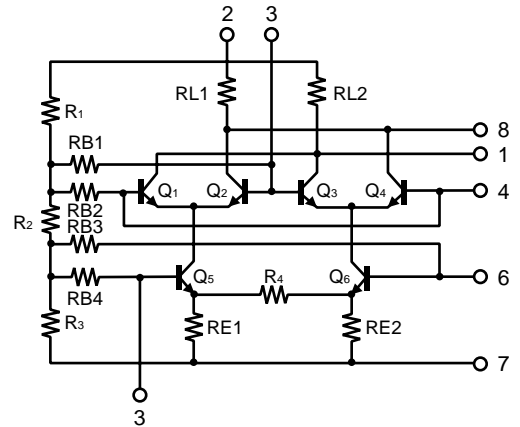

### 9) S-80828ALNP-EAR-T2 (XA0834)

Pin Assignment

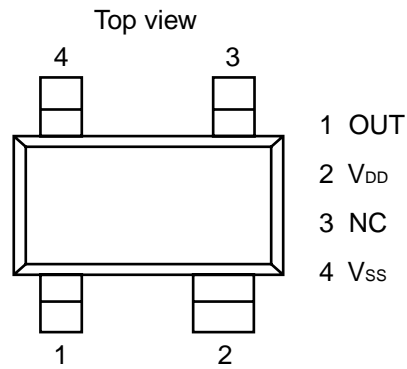

Block Diagram

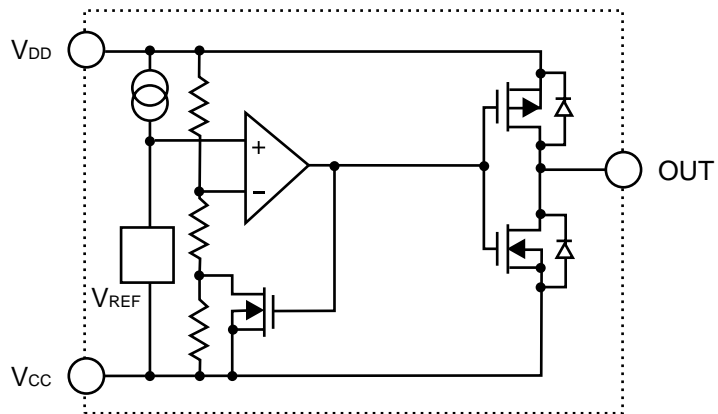

**10) BR24C64F-E2 (XA0669)**

Block Diagram

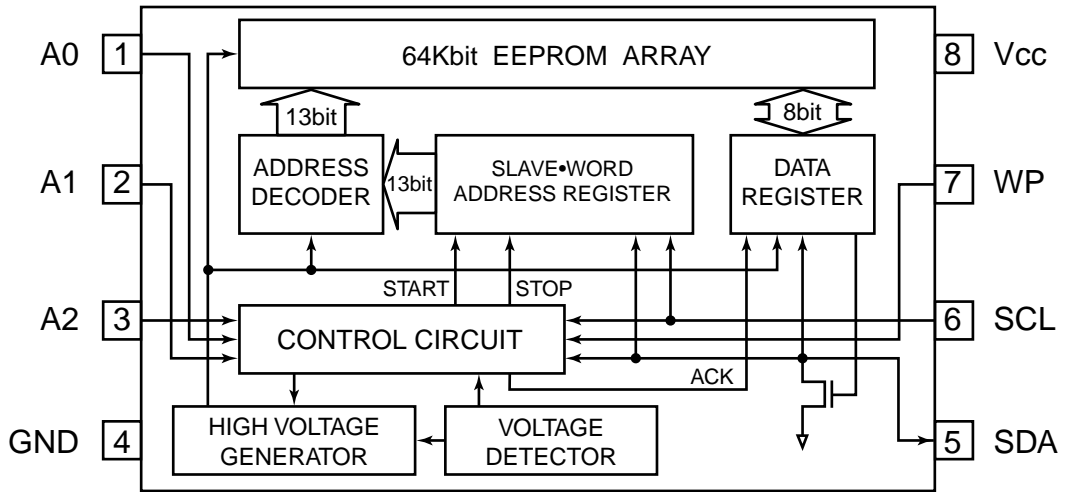

Pin Assignment

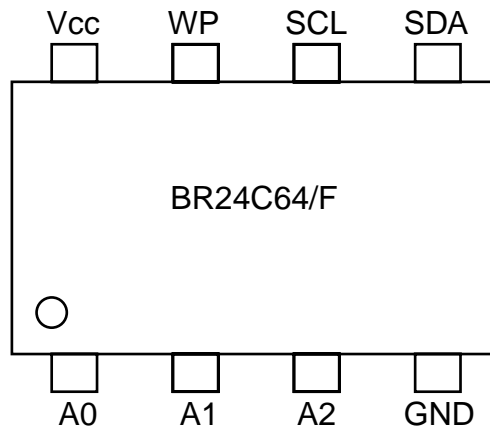

**11) S-81230SG-QB-X (XA0833)**

Pin Assignment

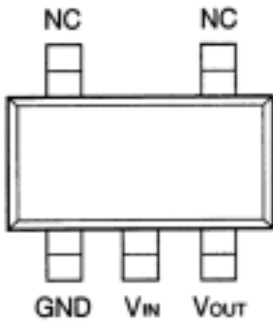

Block Diagram

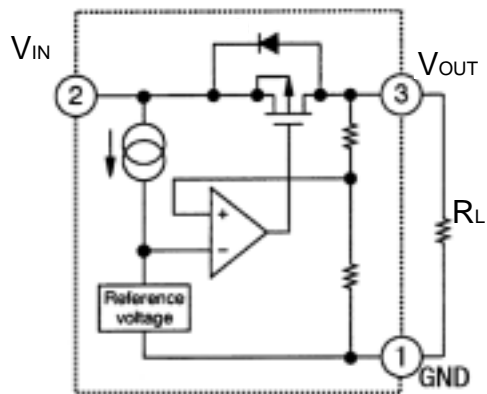

## 12) uPC2757T-E3 (XA0743)

### Terminal Connection

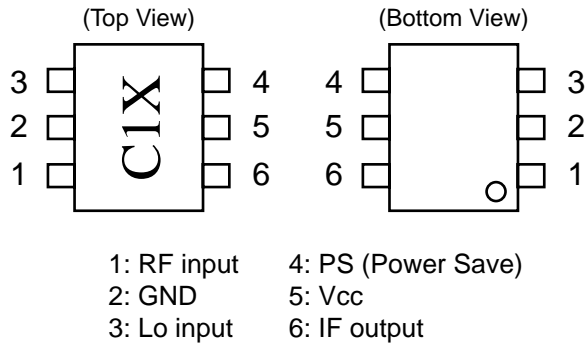

### Block Diagram

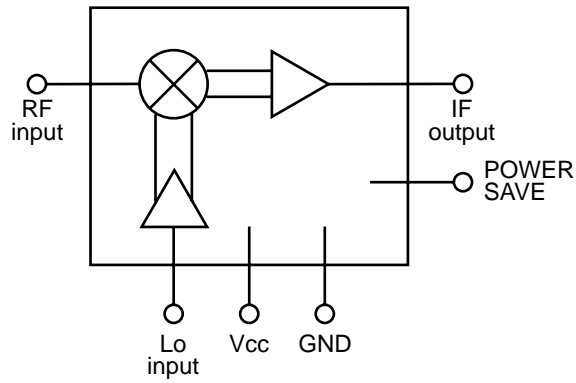

## 13) TC7SET08FU (XA0586)

### Pin Assignment

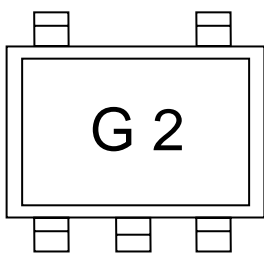

### Block Diagram

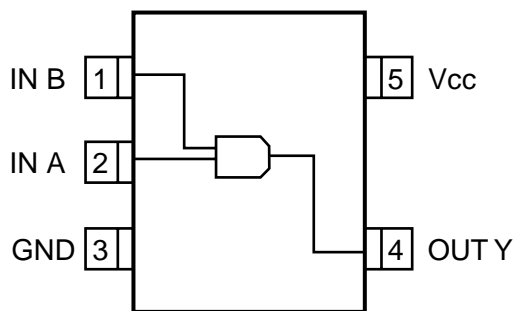

# 14)LA3335M (XA0786)

## Pin Assignment

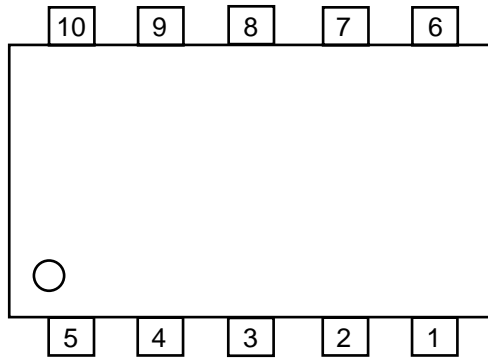

- 1: Input
- 2: PLL loop filter
- 3: Power supply
- 4: VCO
- 5: NC
- 6: GND
- 7: Stereo indicator filter
- 8: Pilot sync detection
- 9: Decoder output (low)
- 10: Decoder output (high)

## Block Diagram

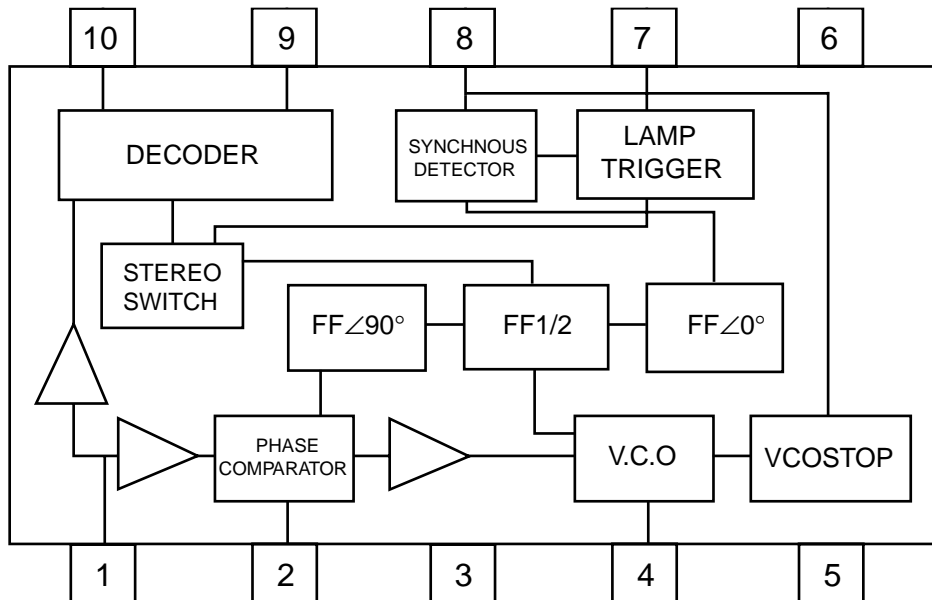



## 15) NJM2107 (XA0850)

Pin Assignment

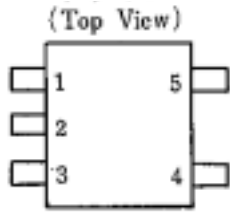

1. +INPUT
2. V<sup>-</sup>
3. -INPUT
4. OUTPUT
5. V<sup>+</sup>

Block Diagram

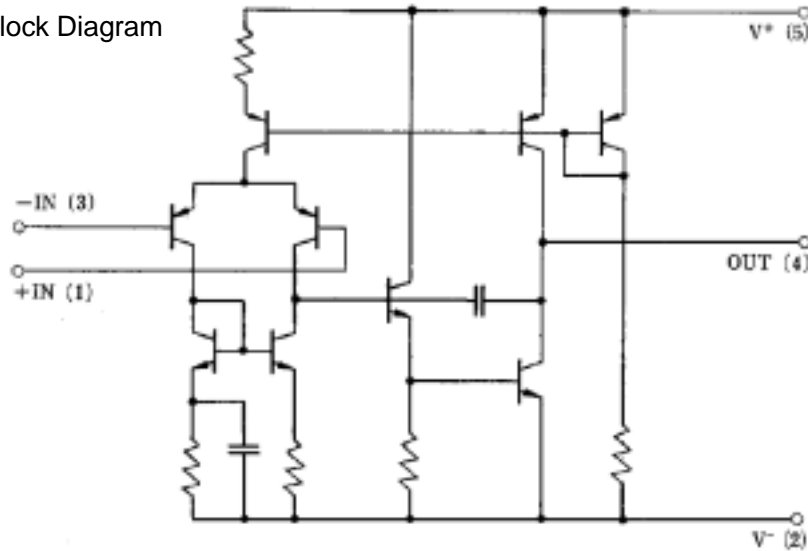

## 16) Transistor, Diode and LED Outline Drawings

1SV308(TPH3) XD0339	DAN235E-TL XD0320	MA2S357-TX XD0337	ISS390 TE61 XD0342	MA2S30400L XD0312	MA2S728-TX XD0315	ISS362 TE85L XD0338
SML-310MTT86 XL0036	2SC4738BL(TE85R) XT0181	2SC5066FT-Y(TE85L) XT0180	2SD2216R-TX XT0135	2SJ144Y(TE85R) XE0019	MA2Z720 XD0367	2SB1132T XT0061
2SK881Y(TE85R) XE0036	UN911H TX XU0092	DTC143TE TL XU0196	XP01501 XU0172	2SK1580 XE0029		
UMC5N TR XU0152	XP1111-TX XU0171					

## 17) LCD connection

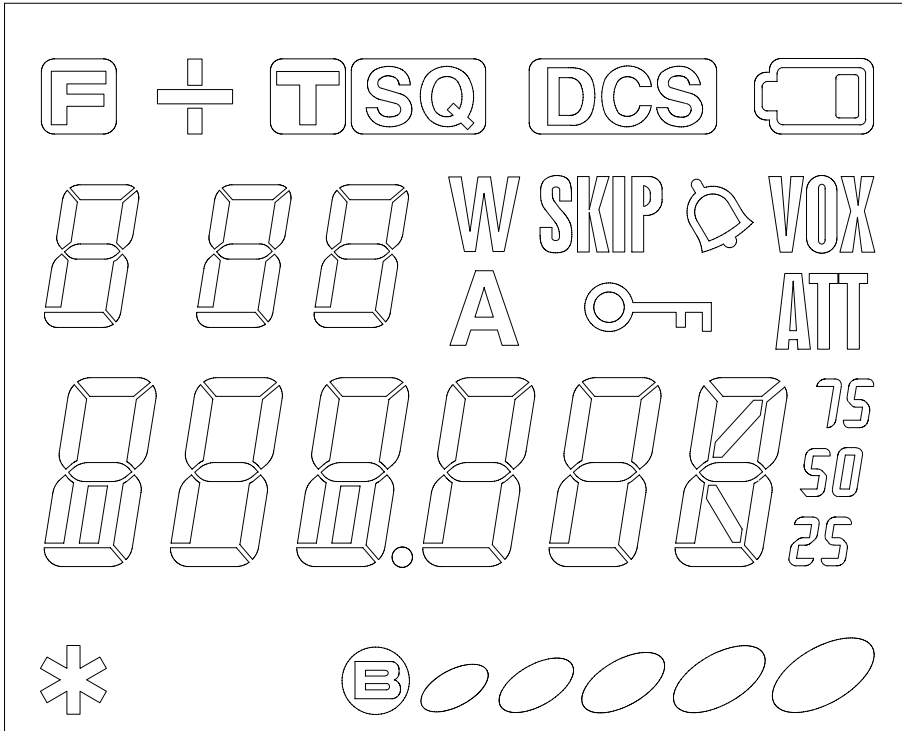

Pin No	COM0	COM1	COM2	COM3
1	COM0	-	-	-
2	-	COM1	-	-
3	-	-	COM2	-
4	-	-	-	COM3
5	D	E	F	C
6	H	I	J	G
7	L	M	N	K
8	P	O	V	W
9	R	S	U	T
10	9c	9b	9a	Y
11	9e	9g	9f	9d
12	8c	8b	8a	X
13	8e	8g	8f	8d
14	7c	7b	7a	Z
15	7e	7g	7f	7d
16	6c	6b	6a	6h
17	6e	6g	6f	6d
18	5c	5b	5a	Q
19	5e	5g	5f	5d
20	4c	4b	4a	4h
21	4e	4g	4f	4d
22	3c	3b	3a	B2
23	3e	3g	3f	3d
24	2c	2b	2a	B1
25	2e	2g	2f	2d
26	1c	1b	1a	A
27	1e	1g	1f	1d

# EXPLODED VIEW

## 1) Front View

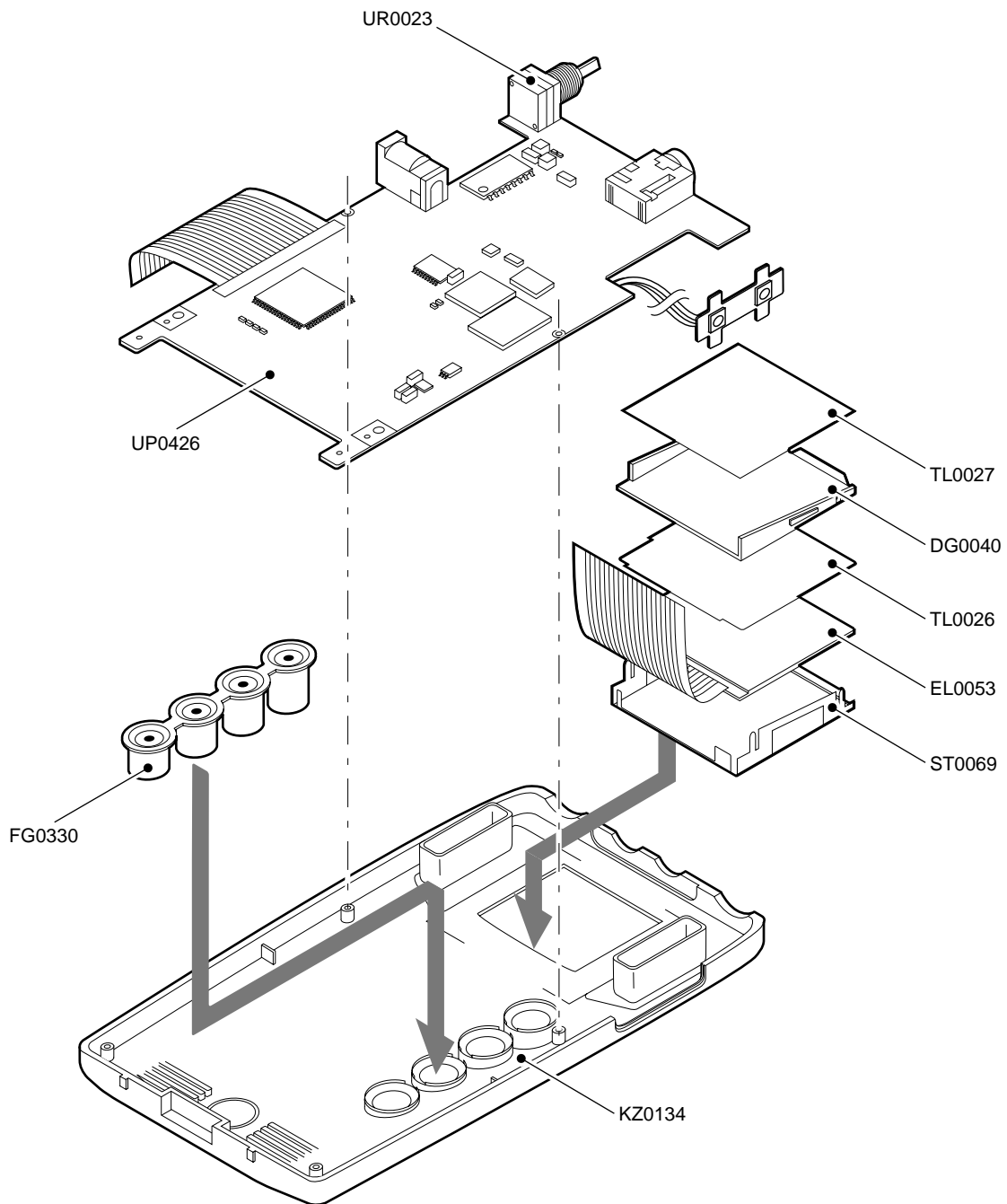

## 2) Bottom View

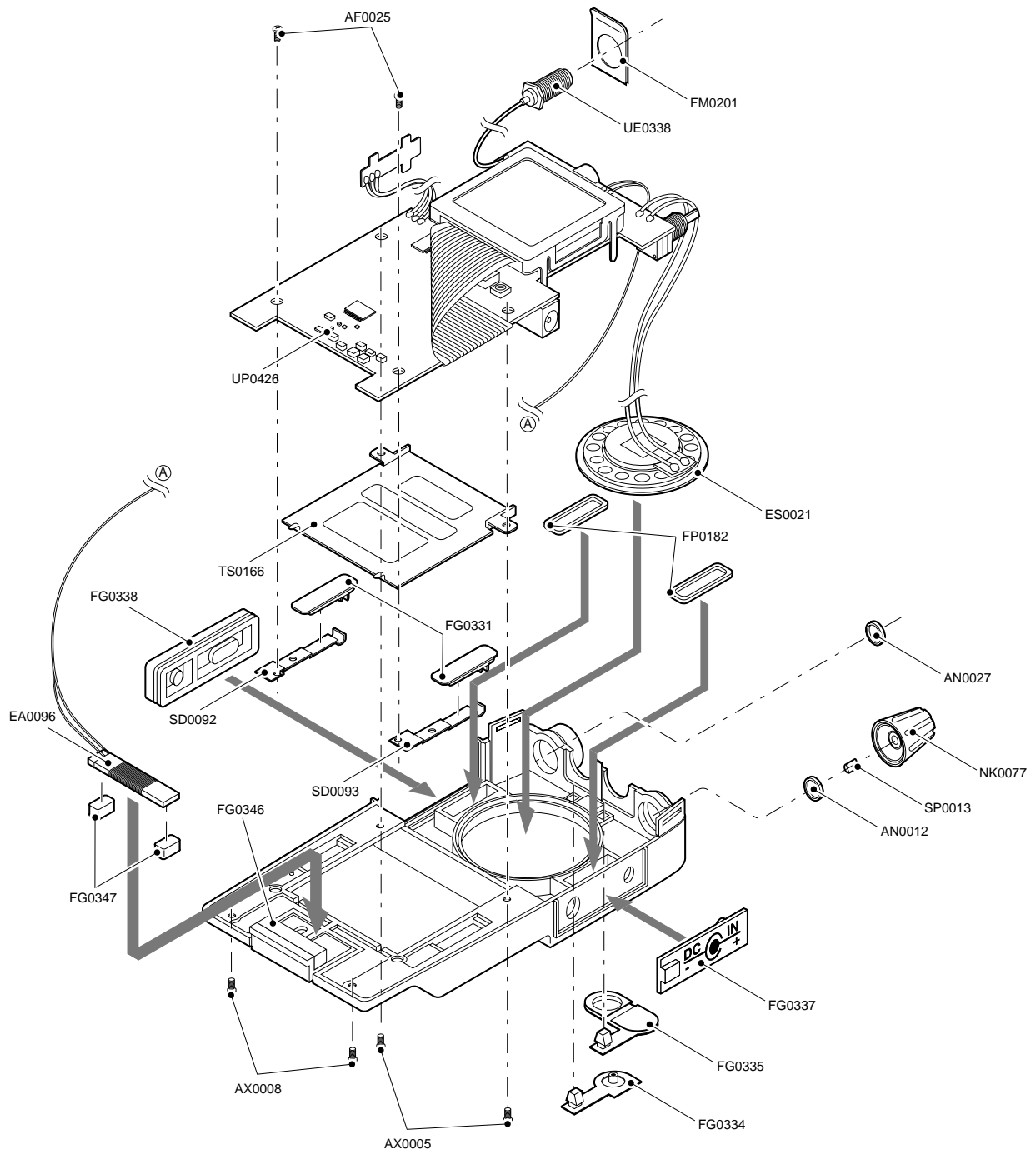

# PARTS LIST

## MAIN Unit

Ref.No.	Parts No.	Descriptin	Parts Name	Ver
C1	CU3111	Chip C.	C1608JB1C104KT-N	
C2	CU3111	Chip C.	C1608JB1C104KT-N	
C3	CU3111	Chip C.	C1608JB1C104KT-N	
C4	CU3111	Chip C.	C1608JB1C104KT-N	
C5	CU3111	Chip C.	C1608JB1C104KT-N	
C6	CU3535	Chip C.	GRM36B102K50PT	
C7	CU3535	Chip C.	GRM36B102K50PT	
C8	CU3535	Chip C.	GRM36B102K50PT	
C9	CU3535	Chip C.	GRM36B102K50PT	
C10	CU3535	Chip C.	GRM36B102K50PT	
C11	CU3535	Chip C.	GRM36B102K50PT	
C12	CU3111	Chip C.	C1608JB1C104KT-N	
C13	CS0395	Chip Tantal	TMCMB0G686MTR	
C14	CS0418	Chip Tantal	TMCMC1C476MTR	
C15	CU3506	Chip C.	GRM36CH050C50PT	
C16	CU3547	Chip C.	GRM36B103K16PT	
C17	CU3535	Chip C.	GRM36B102K50PT	
C18	CS0411	Chip Tantal	4MCM226MATER	
C19	CU3111	Chip C.	C1608JB1C104KT-N	
C20	CU3512	Chip C.	GRM36CH120J50PT	
C21	CU3511	Chip C.	GRM36CH100D50PT	
C22	CU3518	Chip C.	GRM36CH390J50PT	
C23	CU3523	Chip C.	GRM36CH101J50PT	
C24	CS0397	Chip Tantal	TMCP1C105MTR	
C25	CS0395	Chip Tantal	TMCMB0G686MTR	
C26	CS0396	Chip Tantal	TMCP1D104MTR	
C27	CU3535	Chip C.	GRM36B102K50PT	
C28	CU3547	Chip C.	GRM36B103K16PT	
C29	CU3501	Chip C.	GRM36CK0R5C50PT	
C30	CU3535	Chip C.	GRM36B102K50PT	
C31	CU3111	Chip C.	C1608JB1C104KT-N	
C32	CS0397	Chip Tantal	TMCP1C105MTR	
C33	CS0411	Chip Tantal	4MCM226MATER	
C34	CU3523	Chip C.	GRM36CH101J50PT	
C35	CU3535	Chip C.	GRM36B102K50PT	
C36	CU3535	Chip C.	GRM36B102K50PT	
C37	CS0396	Chip Tantal	TMCP1D104MTR	
C38	CU3535	Chip C.	GRM36B102K50PT	
C39	CU3547	Chip C.	GRM36B103K16PT	
C40	CU3111	Chip C.	C1608JB1C104KT-N	
C41	CU3111	Chip C.	C1608JB1C104KT-N	
C42	CS0397	Chip Tantal	TMCP1C105MTR	
C43	CU3111	Chip C.	C1608JB1C104KT-N	
C44	CU3111	Chip C.	C1608JB1C104KT-N	
C45	CU3547	Chip C.	GRM36B103K16PT	
C46	CU3515	Chip C.	GRM36CH220J50PT	
C47	CU3547	Chip C.	GRM36B103K16PT	
C48	CU3111	Chip C.	C1608JB1C104KT-N	
C49	CU3503	Chip C.	GRM36CK020C50PT	
C50	CU3503	Chip C.	GRM36CK020C50PT	
C51	CU3503	Chip C.	GRM36CK020C50PT	
C52	CU3535	Chip C.	GRM36B102K50PT	
C53	CU3111	Chip C.	C1608JB1C104KT-N	

Ref.No.	Parts No.	Descriptin	Parts Name	Ver
C54	CU3503	Chip C.	GRM36CK020C50PT	
C55	CS0397	Chip Tantal	TMCP1C105MTR	
C56	CU3515	Chip C.	GRM36CH220J50PT	
C57	CS0403	Chip Tantal	TMCP1D224MTR	
C58	CU3523	Chip C.	GRM36CH101J50PT	
C59	CU3527	Chip C.	GRM36CH221J25PT	
C60	CU3527	Chip C.	GRM36CH221J25PT	
C61	CU3523	Chip C.	GRM36CH101J50PT	
C62	CU3535	Chip C.	GRM36B102K50PT	
C63	CS0411	Chip Tantal	4MCM226MATER	
C64	CU3503	Chip C.	GRM36CK020C50PT	
C65	CU3535	Chip C.	GRM36B102K50PT	
C66	CU3515	Chip C.	GRM36CH220J50PT	
C67	CU3535	Chip C.	GRM36B102K50PT	
C68	CU3547	Chip C.	GRM36B103K16PT	
C69	CU3111	Chip C.	C1608JB1C104KT-N	
C70	CU3535	Chip C.	GRM36B102K50PT	
C71	CU3527	Chip C.	GRM36CH221J25PT	
C72	CU3514	Chip C.	GRM36CH180J50PT	
C73	CU3510	Chip C.	GRM36CH090D50PT	
C74	CS0395	Chip Tantal	TMCMB0G686MTR	
C75	CU3504	Chip C.	GRM36CJ030C50PT	
C76	CU3551	Chip C.	GRM36B223K16PT	
C77	CS0397	Chip Tantal	TMCP1C105MTR	
C78	CU3527	Chip C.	GRM36CH221J25PT	
C79	CU3547	Chip C.	GRM36B103K16PT	
C80	CU3535	Chip C.	GRM36B102K50PT	
C81	CS0412	Chip Tantal	16MCM156MB2TER	
C82	CU3547	Chip C.	GRM36B103K16PT	
C83	CU3521	Chip C.	GRM36CH680J50PT	
C84	CU3521	Chip C.	GRM36CH680J50PT	
C85	CU3516	Chip C.	GRM36CH270J50PT	
C86	CU3547	Chip C.	GRM36B103K16PT	
C87	CU3517	Chip C.	GRM36CH330J50PT	
C88	CU3520	Chip C.	GRM36CH560J50PT	
C89	CU3517	Chip C.	GRM36CH330J50PT	
C90	CU3547	Chip C.	GRM36B103K16PT	
C91	CU3547	Chip C.	GRM36B103K16PT	
C92	CU3547	Chip C.	GRM36B103K16PT	
C93	CU3547	Chip C.	GRM36B103K16PT	
C94	CU3505	Chip C.	GRM36CH040C50PT	
C95	CU3547	Chip C.	GRM36B103K16PT	
C96	CU3547	Chip C.	GRM36B103K16PT	
C97	CU3111	Chip C.	C1608JB1C104KT-N	
C98	CU3513	Chip C.	GRM36CH150J50PT	
C99	CU3509	Chip C.	GRM36CH080D50PT	
C100	CU3111	Chip C.	C1608JB1C104KT-N	
C101	CU3535	Chip C.	GRM36B102K50PT	
C102	CS0378	Chip Tantal	TMCMC0G107MTR	
C103	CU3535	Chip C.	GRM36B102K50PT	
C104	CU3535	Chip C.	GRM36B102K50PT	
C105	CU3512	Chip C.	GRM36CH120J50PT	
C106	CU3535	Chip C.	GRM36B102K50PT	

Ref.No.	Parts No.	Descriptin	Parts Name	Ver
C107	CU3502	Chip C.	GRM36CK010C50PT	
C108	CU3509	Chip C.	GRM36CH080D50PT	
C109	CU3509	Chip C.	GRM36CH080D50PT	
C110	CU3518	Chip C.	GRM36CH390J50PT	
C111	CU3535	Chip C.	GRM36B102K50PT	
C112	CU3516	Chip C.	GRM36CH270J50PT	
C113	CU3520	Chip C.	GRM36CH560J50PT	
C114	CU3516	Chip C.	GRM36CH270J50PT	
C115	CU3551	Chip C.	GRM36B223K16PT	
C116	CS0408	Chip Tantal	6MCM156MATER	
C117	CU3111	Chip C.	C1608JB1C104KT-N	
C118	CU3535	Chip C.	GRM36B102K50PT	
C119	CU3515	Chip C.	GRM36CH220J50PT	
C120	CU3506	Chip C.	GRM36CH050C50PT	
C121	CU3506	Chip C.	GRM36CH050C50PT	
C122	CU3518	Chip C.	GRM36CH390J50PT	
C123	CU3551	Chip C.	GRM36B223K16PT	
C124	CU3523	Chip C.	GRM36CH101J50PT	
C125	CU3523	Chip C.	GRM36CH101J50PT	
C126	CU3551	Chip C.	GRM36B223K16PT	
C127	CU3535	Chip C.	GRM36B102K50PT	
C128	CU3551	Chip C.	GRM36B223K16PT	
C129	CU3535	Chip C.	GRM36B102K50PT	
C130	CS0404	Chip Tantal	6MCM106MATER	
C131	CU3535	Chip C.	GRM36B102K50PT	
C132	CU3514	Chip C.	GRM36CH180J50PT	
C133	CU3517	Chip C.	GRM36CH330J50PT	
C134	CU3514	Chip C.	GRM36CH180J50PT	
C135	CU3535	Chip C.	GRM36B102K50PT	
C136	CU3535	Chip C.	GRM36B102K50PT	
C137	CU3111	Chip C.	C1608JB1C104KT-N	
C138	CS0408	Chip Tantal	6MCM156MATER	
C139	CU3531	Chip C.	GRM36B471K50PT	
C140	CU3111	Chip C.	C1608JB1C104KT-N	
C141	CU3511	Chip C.	GRM36CH100D50PT	
C142	CU3547	Chip C.	GRM36B103K16PT	
C143	CU3111	Chip C.	C1608JB1C104KT-N	
C144	CU3111	Chip C.	C1608JB1C104KT-N	
C145	CU3111	Chip C.	C1608JB1C104KT-N	
C146	CU3535	Chip C.	GRM36B102K50PT	
C147	CS0408	Chip Tantal	6MCM156MATER	
C148	CU3531	Chip C.	GRM36B471K50PT	
C150	CS0411	Chip Tantal	4MCM226MATER	
C151	CU3531	Chip C.	GRM36B471K50PT	
C152	CU3535	Chip C.	GRM36B102K50PT	
C153	CU3511	Chip C.	GRM36CH100D50PT	
C154	CU3503	Chip C.	GRM36CK020C50PT	
C155	CU3503	Chip C.	GRM36CK020C50PT	
C156	CU3535	Chip C.	GRM36B102K50PT	
C157	CU3547	Chip C.	GRM36B103K16PT	
C158	CU3547	Chip C.	GRM36B103K16PT	
C159	CU3547	Chip C.	GRM36B103K16PT	
C160	CU3547	Chip C.	GRM36B103K16PT	
C161	CU3547	Chip C.	GRM36B103K16PT	
C162	CU3535	Chip C.	GRM36B102K50PT	
C163	CS0408	Chip Tantal	6MCM156MATER	
C164	CU3513	Chip C.	GRM36CH150J50PT	
C165	CU3517	Chip C.	GRM36CH330J50PT	
C166	CU3515	Chip C.	GRM36CH220J50PT	
C167	CU3111	Chip C.	C1608JB1C104KT-N	
C168	CS0396	Chip Tantal	TMCP1D104MTR	

Ref.No.	Parts No.	Descriptin	Parts Name	Ver
C169	CU3111	Chip C.	C1608JB1C104KT-N	
C170	CU3111	Chip C.	C1608JB1C104KT-N	
C171	CU3517	Chip C.	GRM36CH330J50PT	
C172	CU3517	Chip C.	GRM36CH330J50PT	
C173	CU3111	Chip C.	C1608JB1C104KT-N	
C174	CS0398	Chip Tantal	TMCP0J225MTR	
C175	CS0398	Chip Tantal	TMCP0J225MTR	
C176	CU3111	Chip C.	C1608JB1C104KT-N	
C177	CU3111	Chip C.	C1608JB1C104KT-N	
C178	CU3547	Chip C.	GRM36B103K16PT	
C179	CU3513	Chip C.	GRM36CH150J50PT	
C180	CU3531	Chip C.	GRM36B471K50PT	
C181	CS0418	Chip Tantal	TMCMC1C476MTR	
C182	CU3111	Chip C.	C1608JB1C104KT-N	
C183	CU3531	Chip C.	GRM36B471K50PT	
C184	CU3111	Chip C.	C1608JB1C104KT-N	
C185	CU3535	Chip C.	GRM36B102K50PT	
C186	CU3535	Chip C.	GRM36B102K50PT	
C187	CU3531	Chip C.	GRM36B471K50PT	
C188	CU3507	Chip C.	GRM36CH060D50PT	
C189	CU3504	Chip C.	GRM36CJ030C50PT	
C190	CU3504	Chip C.	GRM36CJ030C50PT	
C191	CU3509	Chip C.	GRM36CH080D50PT	
C192	CU0108	Chip C.	LMK212BJ105KG	
C193	CU3111	Chip C.	C1608JB1C104KT-N	
C194	CU3503	Chip C.	GRM36CK020C50PT	
C195	CS0395	Chip Tantal	TMCMC0G686MTR	
C196	CU3111	Chip C.	C1608JB1C104KT-N	
C197	CU3518	Chip C.	GRM36CH390J50PT	
C198	CU3535	Chip C.	GRM36B102K50PT	
C199	CS0411	Chip Tantal	4MCM226MATER	
C200	CS0395	Chip Tantal	TMCMC0G686MTR	
C201	CU3547	Chip C.	GRM36B103K16PT	
C202	CU3547	Chip C.	GRM36B103K16PT	
C203	CU0108	Chip C.	LMK212BJ105KG	
C204	CS0398	Chip Tantal	TMCP0J225MTR	
C205	CU0108	Chip C.	LMK212BJ105KG	
C206	CU3551	Chip C.	GRM36B223K16PT	
C207	CU3551	Chip C.	GRM36B223K16PT	
C208	CS0397	Chip Tantal	TMCP1C105MTR	
C209	CU3111	Chip C.	C1608JB1C104KT-N	
C210	CU3111	Chip C.	C1608JB1C104KT-N	
C211	CU3111	Chip C.	C1608JB1C104KT-N	
C212	CS0398	Chip Tantal	TMCP0J225MTR	
C213	CS0395	Chip Tantal	TMCMC0G686MTR	
C214	CU3111	Chip C.	C1608JB1C104KT-N	
C215	CU3523	Chip C.	GRM36CH101J50PT	
C216	CU3545	Chip C.	GRM36B682K25PT	
C217	CU3545	Chip C.	GRM36B682K25PT	
C218	CU3027	Chip C.	C1608CH1H221JT-AS	
C219	CU3535	Chip C.	GRM36B102K50PT	
C220	CU3551	Chip C.	GRM36B223K16PT	
D1	XD0339	Diode	1SV308(TPH3)	
D2	XD0342	Diode	1SS390 TE61	
D3	XD0342	Diode	1SS390 TE61	
D4	XD0342	Diode	1SS390 TE61	
D5	XD0342	Diode	1SS390 TE61	
D6	XD0342	Diode	1SS390 TE61	
D7	XD0338	Diode	1SS362(TE85L)	
D8	XD0339	Diode	1SV308(TPH3)	
D9	XD0367	Diode	MAZ720	

Ref.No.	Parts No.	Descriptin	Parts Name	Ver
D10	XD0342	Diode	1SS390 TE61	
D11	XD0320	Diode	DAN235E-TL	
D12	XD0338	Diode	1SS362(TE85L)	
D13	XD0320	Diode	DAN235E-TL	
D14	XD0252	Diode	MA741WK TX	
D15	XD0337	Diode	MA2S357-TX	
D16	XD0337	Diode	MA2S357-TX	
D17	XD0339	Diode	1SV308(TPH3)	
D18	XD0342	Diode	1SS390 TE61	
D19	XD0339	Diode	1SV308(TPH3)	
D20	XD0312	Diode	MA2S30400L	
D21	XD0312	Diode	MA2S30400L	
D22	XD0339	Diode	1SV308(TPH3)	
D23	XD0339	Diode	1SV308(TPH3)	
D24	XD0320	Diode	DAN235E-TL	
D25	XD0320	Diode	DAN235E-TL	
D26	XD0339	Diode	1SV308(TPH3)	
D27	XD0339	Diode	1SV308(TPH3)	
D28	XD0339	Diode	1SV308(TPH3)	
D29	XD0339	Diode	1SV308(TPH3)	
D30	XD0315	Diode	MA2S728-TX	
D31	XD0339	Diode	1SV308(TPH3)	
D32	XD0339	Diode	1SV308(TPH3)	
D33	XD0320	Diode	DAN235E-TL	
D34	XD0320	Diode	DAN235E-TL	
D35	XD0320	Diode	DAN235E-TL	
D36	XD0339	Diode	1SV308(TPH3)	
D37	XD0342	Diode	1SS390 TE61	
D38	XD0320	Diode	DAN235E-TL	
D39	XL0036	Diode	SML-310MTT86	
D40	XL0036	Diode	SML-310MTT86	
D41	XD0342	Diode	1SS390 TE61	
D42	XD0320	Diode	DAN235E-TL	
D43	XD0342	Diode	1SS390 TE61	
D44	XD0320	Diode	DAN235E-TL	
D45	XD0339	Diode	1SV308(TPH3)	
D46	XD0342	Diode	1SS390 TE61	
FL1	XC0071	Filter	WF447A SAW FILTER	
FL2	XC0075	Filter	CFUCG450E-TC	
IC1	XA0312	Ic	UPD3140GS-E1	
IC2	XA0665	Ic	TK11816MT	
IC3	XA0743	Ic	UPC2757T-E3	
IC4	XA0743	Ic	UPC2757T-E3	
IC5	XA0833	Ic	S-81230SG-QB-T1	
IC6	XA0666	Ic	TK10931VTL	
IC7	XA0836	Ic	M38227EHP-OTP-X3T	T
IC7	XA0862	Ic	M38224M6H-161HP	E
IC8	XA0667	Ic	TA4101F (TE12L)	
IC9	XA0348	Ic	TC4W53FU(TE12)	
IC10	XA0834	Ic	S-80828ALNP-EAR-T2	
IC11	XA0669	Ic	BR24C64F-E2	
IC12	XA0573	Ic	NJM2904V-TE1	
IC13	XA0786	Ic	LA3335M-TE-L	
IC14	XA0787	Ic	CXA1622M T4	
IC15	XA0599	Ic	MB88347LPFV-G-BND-EF	
IC17	XA0850	Ic	NJM2107F	
IC18	XA0586	Ic	TC7SET08FU-TE85L	
JK1	UJ0015	Jack	HEC2781 010020	
JK2	UJ0019	Jack	HSJ1493-01-010	
L1	QC0560	Coil	LL1608-FH8N2J	
L2	QC0573	Coil	LL1608-FHR10J	

Ref.No.	Parts No.	Descriptin	Parts Name	Ver
L4	QC0586	Coil	LQW1608A15NJ00	
L5	QC0507	Coil	LK16081R0K-T	
L6	QC0507	Coil	LK16081R0K-T	
L7	QC0510	Coil	LK1608330M-T	
L8	QC0631	Coil	LL1608-FSR22J	
L9	QC0631	Coil	LL1608-FSR22J	
L10	QC0631	Coil	LL1608-FSR22J	
L11	QC0506	Coil	LK1608R56K-T	
L12	QC0506	Coil	LK1608R56K-T	
L13	QC0489	Coil	LQH4N221J04	
L15	QC0589	Coil	LQW1608A27NJ00	
L16	QC0497	Coil	LQH4N102K04	
L17	QC0630	Coil	LL1608-FSR18J	
L18	QC0573	Coil	LL1608-FHR10J	
L19	QC0573	Coil	LL1608-FHR10J	
L20	QC0631	Coil	LL1608-FSR22J	
L21	QC0628	Coil	LL1608-FSR12J	
L22	QC0631	Coil	LL1608-FSR22J	
L23	QC0507	Coil	LK16081R0K-T	
L24	QC0570	Coil	LL1608-FH56NJ	
L25	QC0571	Coil	LL1608-FH68NJ	
L26	QC0568	Coil	LL1608-FH39NJ	
L27	QC0566	Coil	LL1608-FH27NJ	
L28	QC0573	Coil	LL1608-FHR10J	
L29	QC0573	Coil	LL1608-FHR10J	
L30	QC0566	Coil	LL1608-FH27NJ	
L31	QC0563	Coil	LL1608-FH15NJ	
L32	QC0566	Coil	LL1608-FH27NJ	
L33	QC0564	Coil	LL1608-FH18NJ	
L34	QC0570	Coil	LL1608-FH56NJ	
L35	QC0570	Coil	LL1608-FH56NJ	
L36	QC0563	Coil	LL1608-FH15NJ	
L37	QC0560	Coil	LL1608-FH8N2J	
L38	QC0563	Coil	LL1608-FH15NJ	
L39	QC0562	Coil	LL1608-FH12NJ	
L40	QH0007	Coil	5CDM 658AN=P3	
L41	QC0570	Coil	LL1608-FH56NJ	
L42	QC0570	Coil	LL1608-FH56NJ	
L43	QC0558	Coil	LL1608-FH5N6S	
L44	QC0556	Coil	LL1608-FH3N9S	
L45	QC0558	Coil	LL1608-FH5N6S	
L46	QC0561	Coil	LL1608-FH10NJ	
L48	QC0562	Coil	LL1608-FH12NJ	
L49	QC0562	Coil	LL1608-FH12NJ	
L50	QC0562	Coil	LL1608-FH12NJ	
L51	QC0507	Coil	LK16081R0K-T	
LCD1	EL0053	LCD	WD-S2304I-7TNNAA	
Q1	XT0135	Transistor	2SD2216R-TX	
Q2	XT0061	Transistor	2SB1132T 100Q	
Q3	XE0036	Transistor	2SK881-Y(TE85R)	
Q4	XU0196	Transistor	DTC143TE TL	
Q5	XE0029	FET	2SK1580-T1	
Q6	XT0180	Transistor	2SC5066FT-Y (TE85L)	
Q7	XU0172	Transistor	XP1501-TX	
Q8	XE0029	FET	2SK1580-T1	
Q9	XT0180	Transistor	2SC5066FT-Y (TE85L)	
Q10	XT0180	Transistor	2SC5066FT-Y (TE85L)	
Q11	XT0180	Transistor	2SC5066FT-Y (TE85L)	
Q12	XU0196	Transistor	DTC143TE TL	
Q13	XT0181	Transistor	2SC4738-BL (TE85R)	
Q14	XT0181	Transistor	2SC4738-BL (TE85R)	

Ref.No.	Parts No.	Descriptin	Parts Name	Ver
Q15	XT0180	Transistor	2SC5066FT-Y (TE85L)	
Q16	XU0092	Transistor	UN911H-TX	
Q17	XT0180	Transistor	2SC5066FT-Y (TE85L)	
Q18	XU0196	Transistor	DTC143TE TL	
Q19	XT0180	Transistor	2SC5066FT-Y (TE85L)	
Q20	XT0180	Transistor	2SC5066FT-Y (TE85L)	
Q21	XT0180	Transistor	2SC5066FT-Y (TE85L)	
Q22	XT0181	Transistor	2SC4738-BL (TE85R)	
Q23	XT0180	Transistor	2SC5066FT-Y (TE85L)	
Q24	XU0196	Transistor	DTC143TE TL	
Q25	XT0135	Transistor	2SD2216R-TX	
Q26	XE0019	FET	2SJ144Y TE85R	
Q27	XT0180	Transistor	2SC5066FT-Y (TE85L)	
Q28	XU0171	Transistor	XP1111-TX	
Q29	XU0171	Transistor	XP1111-TX	
Q30	XU0171	Transistor	XP1111-TX	
Q31	XU0196	Transistor	DTC143TE TL	
Q32	XT0180	Transistor	2SC5066FT-Y (TE85L)	
Q33	XU0092	Transistor	UN911H-TX	
Q34	XT0135	Transistor	2SD2216R-TX	
Q35	XU0196	Transistor	DTC143TE TL	
Q36	XU0196	Transistor	DTC143TE TL	
Q37	XU0196	Transistor	DTC143TE TL	
Q38	XT0180	Transistor	2SC5066FT-Y (TE85L)	
Q39	XU0172	Transistor	XP1501-TX	
Q40	XT0061	Transistor	2SB1132T 100Q	
Q41	XU0092	Transistor	UN911H-TX	
Q42	XE0029	FET	2SK1580-T1	
Q43	XU0092	Transistor	UN911H-TX	
Q44	XU0171	Transistor	XP1111-TX	
Q45	XU0171	Transistor	XP1111-TX	
Q46	XU0171	Transistor	XP1111-TX	
Q47	XU0171	Transistor	XP1111-TX	
Q48	XU0171	Transistor	XP1111-TX	
Q49	XU0196	Transistor	DTC143TE TL	
Q50	XU0092	Transistor	UN911H-TX	
Q51	XU0196	Transistor	DTC143TE TL	
Q52	XU0196	Transistor	DTC143TE TL	
Q53	XE0029	FET	2SK1580-T1	
Q54	XT0135	Transistor	2SD2216R-TX	
R1	RK3550	Chip R.	ERJ2GEJ103X	
R2	RK3526	Chip R.	ERJ2GEJ101X	
R3	RK3521	Chip R.	ERJ2GEJ390X	
R4	RK3521	Chip R.	ERJ2GEJ390X	
R5	RK3542	Chip R.	ERJ2GEJ222X	
R6	RK3522	Chip R.	ERJ2GEJ470X	
R7	RK3526	Chip R.	ERJ2GEJ101X	
R8	RK3550	Chip R.	ERJ2GEJ103X	
R9	RK3542	Chip R.	ERJ2GEJ222X	
R10	RK3546	Chip R.	ERJ2GEJ472X	
R11	RK3514	Chip R.	ERJ2GEJ100X	
R12	RK3542	Chip R.	ERJ2GEJ222X	
R13	RK3522	Chip R.	ERJ2GEJ470X	
R14	RK3522	Chip R.	ERJ2GEJ470X	
R15	RK3550	Chip R.	ERJ2GEJ103X	
R16	RK3542	Chip R.	ERJ2GEJ222X	
R17	RK3542	Chip R.	ERJ2GEJ222X	
R18	RK3522	Chip R.	ERJ2GEJ470X	
R19	RK3550	Chip R.	ERJ2GEJ103X	
R20	RK3526	Chip R.	ERJ2GEJ101X	
R21	RK3562	Chip R.	ERJ2GEJ104X	

Ref.No.	Parts No.	Descriptin	Parts Name	Ver
R22	RK3522	Chip R.	ERJ2GEJ470X	
R24	RK3530	Chip R.	ERJ2GEJ221X	
R25	RK3558	Chip R.	ERJ2GEJ473X	
R26	RK3562	Chip R.	ERJ2GEJ104X	
R27	RK3530	Chip R.	ERJ2GEJ221X	
R28	RK3534	Chip R.	ERJ2GEJ471X	
R29	RK3548	Chip R.	ERJ2GEJ682X	
R30	RK3550	Chip R.	ERJ2GEJ103X	
R31	RK3538	Chip R.	ERJ2GEJ102X	
R32	RK3550	Chip R.	ERJ2GEJ103X	
R33	RK3542	Chip R.	ERJ2GEJ222X	
R34	RK3557	Chip R.	ERJ2GEJ393X	
R35	RK3550	Chip R.	ERJ2GEJ103X	
R36	RK3542	Chip R.	ERJ2GEJ222X	
R37	RK3534	Chip R.	ERJ2GEJ471X	
R38	RK3542	Chip R.	ERJ2GEJ222X	
R39	RK3546	Chip R.	ERJ2GEJ472X	
R40	RK3546	Chip R.	ERJ2GEJ472X	
R41	RK3550	Chip R.	ERJ2GEJ103X	
R42	RK3526	Chip R.	ERJ2GEJ101X	
R43	RK3550	Chip R.	ERJ2GEJ103X	
R44	RK3540	Chip R.	ERJ2GEJ152X	
R45	RK3550	Chip R.	ERJ2GEJ103X	
R46	RK3550	Chip R.	ERJ2GEJ103X	
R47	RK3546	Chip R.	ERJ2GEJ472X	
R48	RK3538	Chip R.	ERJ2GEJ102X	
R49	RK3542	Chip R.	ERJ2GEJ222X	
R50	RK3522	Chip R.	ERJ2GEJ470X	
R51	RK3538	Chip R.	ERJ2GEJ102X	
R52	RK3542	Chip R.	ERJ2GEJ222X	
R53	RK3550	Chip R.	ERJ2GEJ103X	
R54	RK3570	Chip R.	ERJ2GEJ474X	
R55	RK3558	Chip R.	ERJ2GEJ473X	
R56	RK3550	Chip R.	ERJ2GEJ103X	
R57	RK3558	Chip R.	ERJ2GEJ473X	
R58	RK3522	Chip R.	ERJ2GEJ470X	
R59	RK3532	Chip R.	ERJ2GEJ331X	
R60	RK3542	Chip R.	ERJ2GEJ222X	
R61	RK3550	Chip R.	ERJ2GEJ103X	
R62	RK3550	Chip R.	ERJ2GEJ103X	
R63	RK3538	Chip R.	ERJ2GEJ102X	
R64	RK3550	Chip R.	ERJ2GEJ103X	
R65	RK3522	Chip R.	ERJ2GEJ470X	
R66	RK3562	Chip R.	ERJ2GEJ104X	
R67	RK3546	Chip R.	ERJ2GEJ472X	
R68	RK3526	Chip R.	ERJ2GEJ101X	
R69	RK3542	Chip R.	ERJ2GEJ222X	
R70	RK3542	Chip R.	ERJ2GEJ222X	
R71	RK3538	Chip R.	ERJ2GEJ102X	
R72	RK3550	Chip R.	ERJ2GEJ103X	
R73	RK3530	Chip R.	ERJ2GEJ221X	
R74	RK3550	Chip R.	ERJ2GEJ103X	
R75	RK3566	Chip R.	ERJ2GEJ224X	
R76	RK3526	Chip R.	ERJ2GEJ101X	
R77	RK3522	Chip R.	ERJ2GEJ470X	
R78	RK3522	Chip R.	ERJ2GEJ470X	
R79	RK3550	Chip R.	ERJ2GEJ103X	
R80	RK3550	Chip R.	ERJ2GEJ103X	
R81	RK3566	Chip R.	ERJ2GEJ224X	
R82	RK3538	Chip R.	ERJ2GEJ102X	
R83	RK3522	Chip R.	ERJ2GEJ470X	



Ref.No.	Parts No.	Descriptin	Parts Name	Ver
R84	RK3542	Chip R.	ERJ2GEJ222X	
R85	RK3554	Chip R.	ERJ2GEJ223X	
R86	RK3546	Chip R.	ERJ2GEJ472X	
R87	RK3542	Chip R.	ERJ2GEJ222X	
R88	RK3542	Chip R.	ERJ2GEJ222X	
R89	RK3550	Chip R.	ERJ2GEJ103X	
R90	RK3556	Chip R.	ERJ2GEJ333X	
R91	RK3558	Chip R.	ERJ2GEJ473X	
R92	RK3550	Chip R.	ERJ2GEJ103X	
R93	RK3558	Chip R.	ERJ2GEJ473X	
R94	RK3558	Chip R.	ERJ2GEJ473X	
R95	RK3562	Chip R.	ERJ2GEJ104X	
R96	RK3554	Chip R.	ERJ2GEJ223X	
R97	RK3562	Chip R.	ERJ2GEJ104X	
R98	RK3522	Chip R.	ERJ2GEJ470X	
R99	RK3574	Chip R.	ERJ2GEJ105X	
R100	RK3542	Chip R.	ERJ2GEJ222X	
R101	RK3550	Chip R.	ERJ2GEJ103X	
R102	RK3550	Chip R.	ERJ2GEJ103X	
R103	RK3562	Chip R.	ERJ2GEJ104X	
R104	RK3559	Chip R.	ERJ2GEJ563X	
R105	RK3554	Chip R.	ERJ2GEJ223X	
R106	RK3558	Chip R.	ERJ2GEJ473X	
R107	RK3570	Chip R.	ERJ2GEJ474X	
R108	RK3553	Chip R.	ERJ2GEJ183X	
R109	RK3562	Chip R.	ERJ2GEJ104X	
R110	RK3566	Chip R.	ERJ2GEJ224X	
R111	RK3550	Chip R.	ERJ2GEJ103X	
R112	RK3538	Chip R.	ERJ2GEJ102X	
R113	RK3546	Chip R.	ERJ2GEJ472X	
R114	RK3538	Chip R.	ERJ2GEJ102X	
R115	RK3501	Chip R.	ERJ2GE0R00X	
R116	RK3522	Chip R.	ERJ2GEJ470X	
R117	RK3550	Chip R.	ERJ2GEJ103X	
R118	RK3542	Chip R.	ERJ2GEJ222X	
R119	RK3552	Chip R.	ERJ2GEJ153X	
R120	RK3526	Chip R.	ERJ2GEJ101X	
R121	RK3550	Chip R.	ERJ2GEJ103X	
R122	RK3559	Chip R.	ERJ2GEJ563X	
R123	RK3550	Chip R.	ERJ2GEJ103X	
R124	RK3558	Chip R.	ERJ2GEJ473X	
R125	RK3550	Chip R.	ERJ2GEJ103X	
R126	RK3568	Chip R.	ERJ2GEJ334X	
R127	RK3553	Chip R.	ERJ2GEJ183X	
R128	RK3534	Chip R.	ERJ2GEJ471X	
R129	RK3542	Chip R.	ERJ2GEJ222X	
R130	RK3550	Chip R.	ERJ2GEJ103X	
R131	RK3562	Chip R.	ERJ2GEJ104X	
R132	RK3554	Chip R.	ERJ2GEJ223X	
R133	RK3554	Chip R.	ERJ2GEJ223X	
R134	RK3548	Chip R.	ERJ2GEJ682X	
R135	RK3526	Chip R.	ERJ2GEJ101X	
R136	RK3550	Chip R.	ERJ2GEJ103X	
R137	RK3562	Chip R.	ERJ2GEJ104X	
R138	RK3554	Chip R.	ERJ2GEJ223X	
R139	RK3538	Chip R.	ERJ2GEJ102X	
R140	RK3550	Chip R.	ERJ2GEJ103X	
R141	RK3562	Chip R.	ERJ2GEJ104X	
R142	RK3550	Chip R.	ERJ2GEJ103X	
R143	RK3550	Chip R.	ERJ2GEJ103X	
R144	RK3550	Chip R.	ERJ2GEJ103X	

Ref.No.	Parts No.	Descriptin	Parts Name	Ver
R145	RK3550	Chip R.	ERJ2GEJ103X	
R146	RK3574	Chip R.	ERJ2GEJ105X	
R147	RK3554	Chip R.	ERJ2GEJ223X	
R148	RK3562	Chip R.	ERJ2GEJ104X	
R149	RK3552	Chip R.	ERJ2GEJ153X	
R150	RK3566	Chip R.	ERJ2GEJ224X	
R151	RK3570	Chip R.	ERJ2GEJ474X	
R152	RK3538	Chip R.	ERJ2GEJ102X	
R153	RA0009	Chip R.	EXBV8V102JV	
R154	RK3522	Chip R.	ERJ2GEJ470X	
R155	RK3542	Chip R.	ERJ2GEJ222X	
R156	RK3534	Chip R.	ERJ2GEJ471X	
R157	RK3552	Chip R.	ERJ2GEJ153X	
R158	RK3548	Chip R.	ERJ2GEJ682X	
R159	RK3562	Chip R.	ERJ2GEJ104X	
R160	RK3550	Chip R.	ERJ2GEJ103X	
R161	RK3522	Chip R.	ERJ2GEJ470X	
R162	RK3552	Chip R.	ERJ2GEJ153X	
R163	RK3556	Chip R.	ERJ2GEJ333X	
R164	RK3557	Chip R.	ERJ2GEJ393X	
R165	RK3555	Chip R.	ERJ2GEJ273X	
R166	RK3557	Chip R.	ERJ2GEJ393X	
R167	RK3546	Chip R.	ERJ2GEJ472X	
R168	RK3542	Chip R.	ERJ2GEJ222X	
R169	RK3566	Chip R.	ERJ2GEJ224X	
R170	RK3568	Chip R.	ERJ2GEJ334X	
R171	RK3538	Chip R.	ERJ2GEJ102X	
R172	RK3568	Chip R.	ERJ2GEJ334X	
R173	RK3522	Chip R.	ERJ2GEJ470X	
R174	RK3568	Chip R.	ERJ2GEJ334X	
R175	RK3574	Chip R.	ERJ2GEJ105X	
R176	RK3528	Chip R.	ERJ2GEJ151X	
R177	RK3522	Chip R.	ERJ2GEJ470X	
R178	RK3540	Chip R.	ERJ2GEJ152X	
R179	RK3550	Chip R.	ERJ2GEJ103X	
R180	RK3001	Chip R.	MCR03EZHJ000	
R181	RK3540	Chip R.	ERJ2GEJ152X	
R182	RK3550	Chip R.	ERJ2GEJ103X	
R183	RK3528	Chip R.	ERJ2GEJ151X	
R184	RK3528	Chip R.	ERJ2GEJ151X	
R185	RK3550	Chip R.	ERJ2GEJ103X	
R186	RK3550	Chip R.	ERJ2GEJ103X	
R187	RK3562	Chip R.	ERJ2GEJ104X	
R188	RK3543	Chip R.	ERJ2GEJ272X	
R189	RK3556	Chip R.	ERJ2GEJ333X	
R190	RK3558	Chip R.	ERJ2GEJ473X	
R191	RK3501	Chip R.	ERJ2GE0R00X	
R192	RK3528	Chip R.	ERJ2GEJ151X	
R193	RK3562	Chip R.	ERJ2GEJ104X	
R196	RK0105	Chip R.	ERJ6GEYJ2R2V	
R198	RK3034	Chip R.	MCR03EZHJ471	
R200	RK3538	Chip R.	ERJ2GEJ102X	
R201	RK3574	Chip R.	ERJ2GEJ105X	
R203	RK3568	Chip R.	ERJ2GEJ334X	
RE1	UR0023	Chip R.	TP70N00AE20	
TC1	CT0045	Trimmer	SMD3-010C1	
VR1	RH0142	Volume	MVR22HXBRN103	
X1	XQ0140	Crystal	SX-2112	
X2	XQ0132	Crystal	CSA-309 4.194304MHZ	
XF1	XF0047	Filter	RE63SM113 38.850MHZ	
	TS0168		VCO CASE B	

Ref.No.	Parts No.	Descriptin	Parts Name	Ver
	TS0167		VCO CASE A	
	UP0426	PCB	DJX3 INTEGRATED	0.5
	TL0027		REFLECTIVE SHEET	
	TL0026		DIFFUSION SHEET	
	ST0069		LCD HOLDER	
	DG0040		LCD LIGHT	

## SW Unit

Ref.No.	Parts No.	Descriptin	Parts Name	Ver
SW301	UU0027	Switch	SKQGAA	
SW302	UU0027	Switch	SKQGAA	
W301	MGCL02AA	Wire	#30G02-020-02	
W302	MRCL02GG	Wire	#30RH1-020-H1	
W303	MBCL02GG	Wire	#30BH1-020-H1	

Ref.No.	Parts No.	Descriptin	Parts Name	Ver
	PH0009A		Warranty	T
	DS0446		Spec.sheet	
	PR0478		Serial seal	2.1
	PR0452		FCC homeuse label	T
	PR0447		FCC warning label	T
	HK0538		Pacage	
	HU0175		Inner DJ-S40Z	
	HU0176		10 Inner DJ-S40Z	
	HM0201		Carton	
	HP0006Z		Protection bag	
	PR0513		Label N-13x13	T
	PR0514		Label E-10x49	2
	#G1024		Belt clip unit	

## Mechanical Parts

Ref.No.	Parts No.	Descriptin	Parts Name	Ver
W1	MRCL03AA	Wire	#30R02-030-02	
W2	MBCLH4GG	Wire	#30BH1-045-H1	
W3	MACK02GG	Wire	#28AH1-020-H1	
	FG0337		DC CAP	
	ES0021		T032S23A0000	
	FG0331		TERMINAL RUBBER	2
	AN0012		RND N7X0.75 BR/B.ZN	
	FP0179		REAR PANEL	
	FG0334		SP CAP	
	FG0335		JACK RUBBER	
	FG0338		FUNC RUBBER	
	YX0032		LCDTAPE	
	AN0027		ANTENNA NUT XH720	
	KZ0137		REAR CASE	
	FG0330		KEY RUBBER	
	TS0166		RF SHIERD	
	SD0093		TERMINAL R	
	SD0092		TERMINAL L	
	NK0078		VOL NOB X3	
	DP0139		LCD PANEL	
	KZ0136		FRONT CASE	
	AX0005		OPH P 1.7+5.5 FE NI3	2
	FG0347		ANTENNA cushion	
	EA0096		ANTENNA EA96	
	FM0201		ANTENNA EARTH	
	AX0008		OPH P 1.7+4 FEBC3	2
	FG0346		Cushion A	
	FP0182		SP cushion	2
	SP0013		LECTRA #7800	
	UE0338		SMA 19-16-3TGG	
	AF0025		OPH M2+2.5 FE/N1	2

## Packing

Ref.No.	Parts No.	Descriptin	Parts Name	Ver
	EA0081		Antenna	
	PS0384		Instruction Manual	

# ADJUSTMENT

## 1) How to enter the adjustment mode

Press the key like the below after Key Lock.

BANK > SCAN > V/P/M > BANK > V/P/M > SCAN

## 2) Adjustment

Display	Memory Content	Adjust point
FrEq	Frequency Adjustment	TC1
FrEq	Maximum AF output level Adjustment	L40
PLt-F	Stereo Adjustment	VR1
1n1	BP1 Squelch level 1 Setting	SCAN key
1nF	BP1 Squelch level 5 Setting	SCAN key
2n1	BP2 Squelch level 1 Setting	SCAN key
2nF	BP2 Squelch level 5 Setting	SCAN key
3n1	BP3 Squelch level 1 Setting	SCAN key
3nF	BP3 Squelch level 5 Setting	SCAN key
4n1	BP4 Squelch level 1 Setting	SCAN key
4nF	BP4 Squelch level 5 Setting	SCAN key
5n1	BP5 Squelch level 1 Setting	SCAN key
5nF	BP5 Squelch level 5 Setting	SCAN key
6n1	BP6 Squelch level 1 Setting	SCAN key
6nF	BP6 Squelch level 5 Setting	SCAN key
3S1	BP3 S meter level 1 Setting	SCAN key
3SF	BP3 S meter level 5 Setting	SCAN key
Wn1	WFM Squelch level 1 Setting	SCAN key
WnF	WFM Squelch level 5 Setting	SCAN key
ws1	WFM S meter level 1 Setting	SCAN key
wsF	WFM S meter level 5 Setting	SCAN key
dSPv	Reduction Battery Display Setting	SCAN key
bUGvoL	Wiretapping Detector Sound Volume Setting	SCAN key

When want to change the display, press the V/P/M key or BANK key.

Item	Adjustment Content	Specification
Reference Frequency Adjustment	Adjust the TC1 to 391.05MHz. Display : FrE9 Adjust Point : TC1 Check Point : TP2	391.05MHz + -100Hz
AF output Adjustment	AF maximum output Display : FrEq Input the 142.6MHz of 30dBu to the test unit which modulation is 1KHz 3.5KHz and adjust the L40 to become maximum AF level.  Adjust Point : L40 (A side of main board)	More than 20mw(8Ω)
Stereo Adjustment	Pilot Frequency Adjustment Display:pLt-F Input the 90.5MHz of 30dBu (no modulation) and adjust the VR1 to 76KHz of the Pilot Frequency. (Connect the Ear-phone plug when adjust this item.)  Adjust Point : VR1 Check Point : TP15	76KHz + -1KHz
SQL Adjustment ( BP1 )	SQL level 1 Adjustment Display : 1n1 Input the 14.3MHz of -8dBu (standard modulation), and press the SCAN key. Check if can hear the BEEP sound, when press the SCAN key.  SQL level 5 Adjustment Display : 1nF Input the 14.3MHz of -2dBu (standard modulation), and press the SCAN key. Check if can hear the BEEP sound, when press the SCAN key.	
SQL Adjustment ( BP2 )	SQL level 1 Adjustment Display : 2n1 Input the 109.15MHz of -10dBu (standard modulation), and press the SCAN key. Check if can hear the BEEP sound, when press the SCAN key.  SQL level 5 Adjustment Display : 2nF Input the 109.15MHz of -4dBu (standard modulation), and press the SCAN key. Check if can hear the BEEP sound, when press the SCAN key.	
SQL Adjustment ( BP3 )	SQL level 1 Adjustment Display : 3n1 Input the 145.13MHz of -8dBu (standard modulation), and press the SCAN key. Check if can hear the BEEP sound.  SQL level 5 Adjustment Display : 3nF Input the 145.13MHz of -2dBu (standard modulation), and press the SCAN key. Check if can hear the BEEP sound.	
SQL Adjustment ( BP4 )	SQL level 1 Adjustment Display : 4n1 Input the 290.15MHz of -8dBu (standard modulation), and press the SCAN key. Check if can hear the BEEP sound.  SQL level 5 Adjustment Display : 4nF Input the 290.15MHz of -2dBu (standard modulation), and press the SCAN key. Check if can hear the BEEP sound.	

Item	Adjustment Content	Specification
SQL Adjustment ( BP5 )	<p>SQL level 1 Adjustment    Display : 5n1  Input the 435.13MHz of -6dBu (standard modulation), and press the SCAN key.  Check if can hear the BEEP sound.</p> <p>SQL level 5 Adjustment    Display : 5nF  Input the 435.13MHz of 0dBu (standard modulation), and press the SCAN key.  Check if can hear the BEEP sound.</p>	
SQL Adjustment ( BP6 )	<p>SQL level 1 Adjustment    Display : 6n1  Input the 797.1MHz of -4dBu (standard modulation), and press the SCAN key.  Check if can hear the BEEP sound.</p> <p>SQL level 5 Adjustment    Display : 6nF  Input the 797.1MHz of 2dBu (standard modulation), and press the SCAN key.  Check if can hear the BEEP sound.</p>	
S Meter Adjustment ( BP3 )	<p>S Meter level 1 Adjustment    Display : 3S1  Input the 145.13MHz of -5dBu (standard modulation), and press the SCAN key.  Check if can hear the BEEP sound.</p> <p>S Meter level 5 Adjustment    Display : 3SF  Input the 145.13MHz of 15dBu (standard modulation), and press the SCAN key.  Check if can hear the BEEP sound.</p>	
SQL Adjustment ( WFM )	<p>SQL level 1 Adjustment    Display : Wn1  Input the 90.5MHz of 6dBu which modulation is 22.5KHz, and press the SCAN key.  Check if can hear the BEEP sound.</p> <p>SQL level 5 Adjustment    Display : WnF  Input the 90.5MHz of 18dBu which modulation is 22.5KHz, and press the SCAN key.  Check if can hear the BEEP sound.</p>	
S Meter Adjustment ( WFM )	<p>S Meter level 1 Adjustment    Display : WS1  Input the 90.5MHz of 13dBu which modulation is 22.5KHz, and press the SCAN key.  Check if can hear the BEEP sound.</p> <p>S Meter level 5 Adjustment    Display : WSF  Input the 90.5MHz of 20dBu which modulation is 22.5KHz, and press the SCAN key.  Check if can hear the BEEP sound.</p>	
Battery Indication Setting	<p>Turn on the Reduction Battery Character    Display : dSpv  Change the input voltage from 4.5V to 3.8V, and press the SCAN key.</p> <p>Check if can hear the BEEP sound.  ( After checking return the voltage to 4.5V.)</p>	
	<p>After finishing all adjustment items, press the FUNC key, and then change the mode from adjustment mood.  ( If want to change the mode before finish the adjustment, press the FUNC key before get off the adjustment mode.)</p>	

# PC BOARD VIEW

## 1) DJ-X3T /X3E Side A

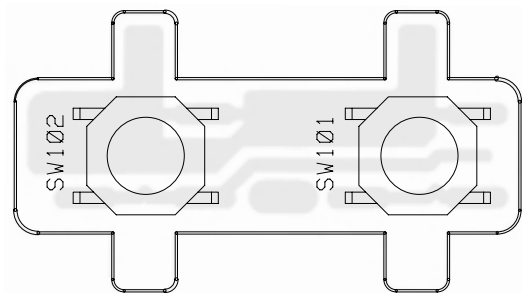
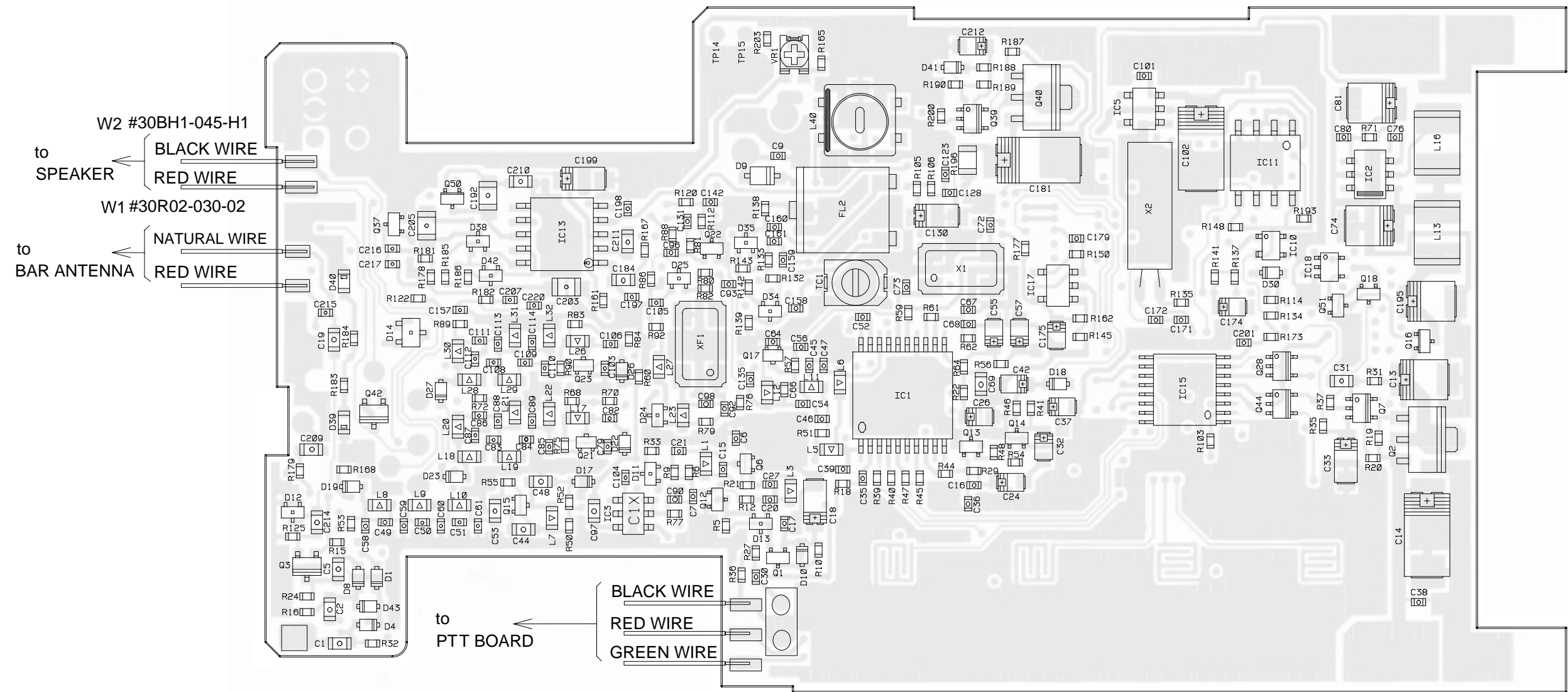

2) DJ-X3T /X3E Side B

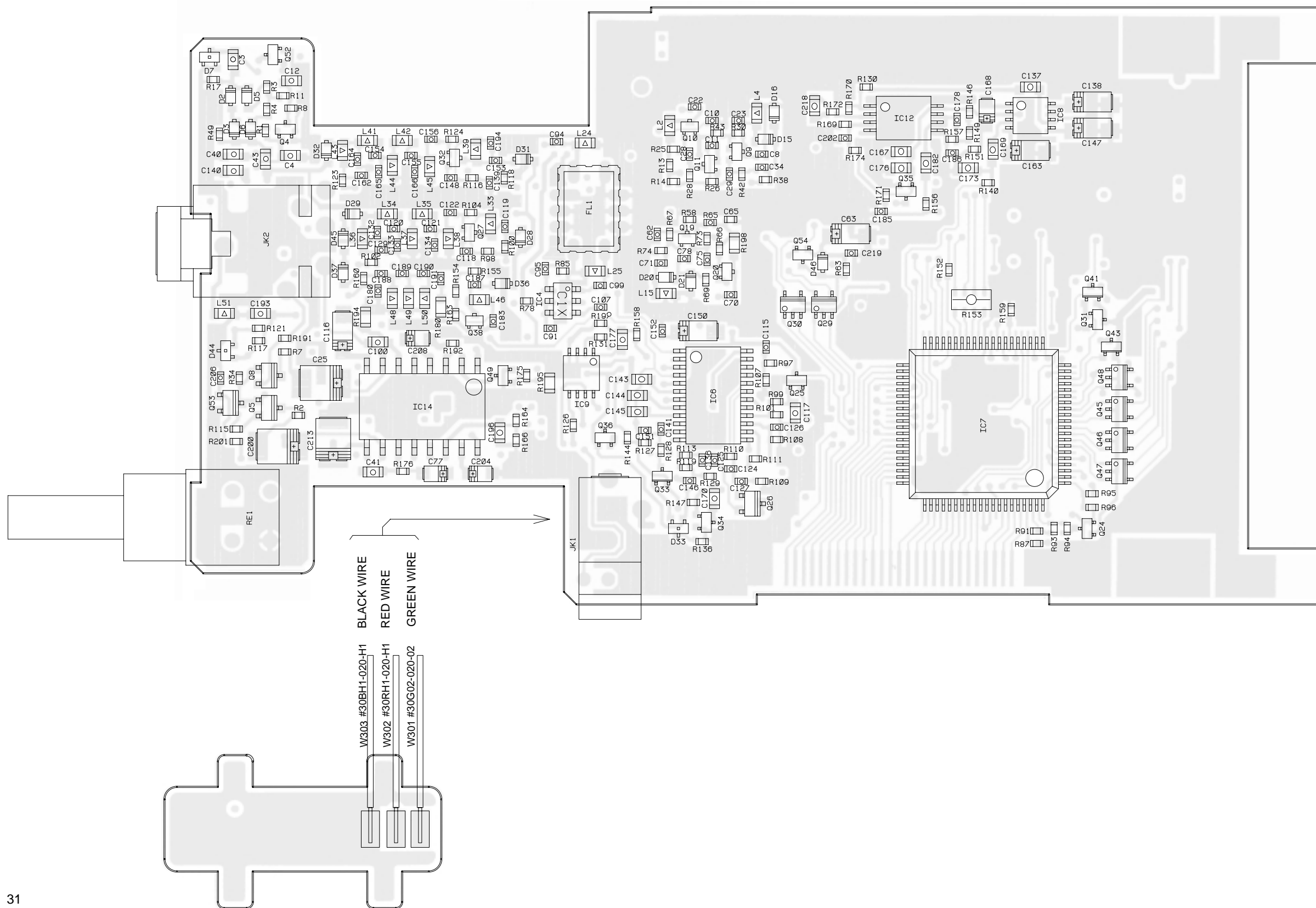

# SCHEMATIC DIAGRAM

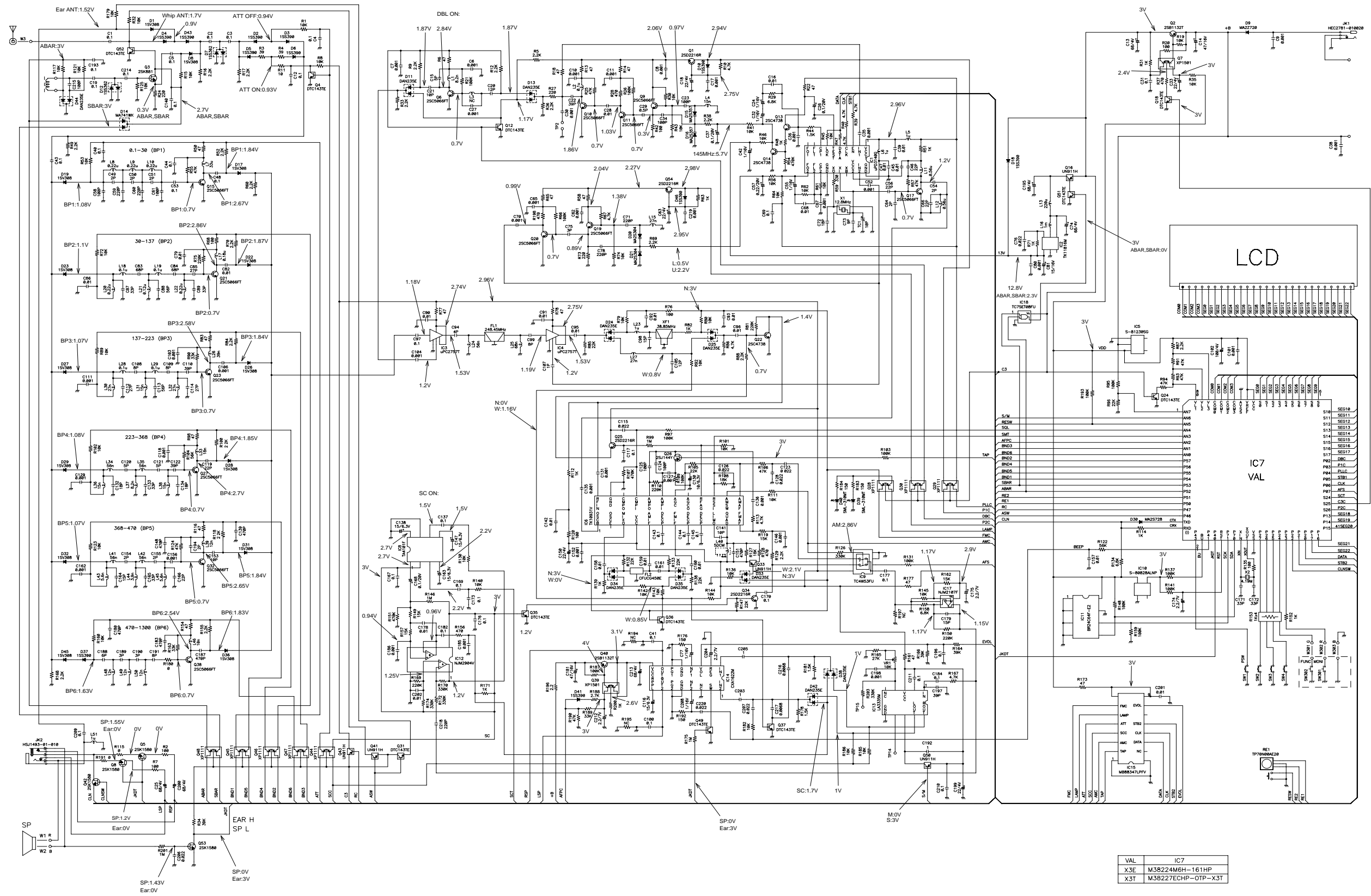



# BLOCK DIAGRAM

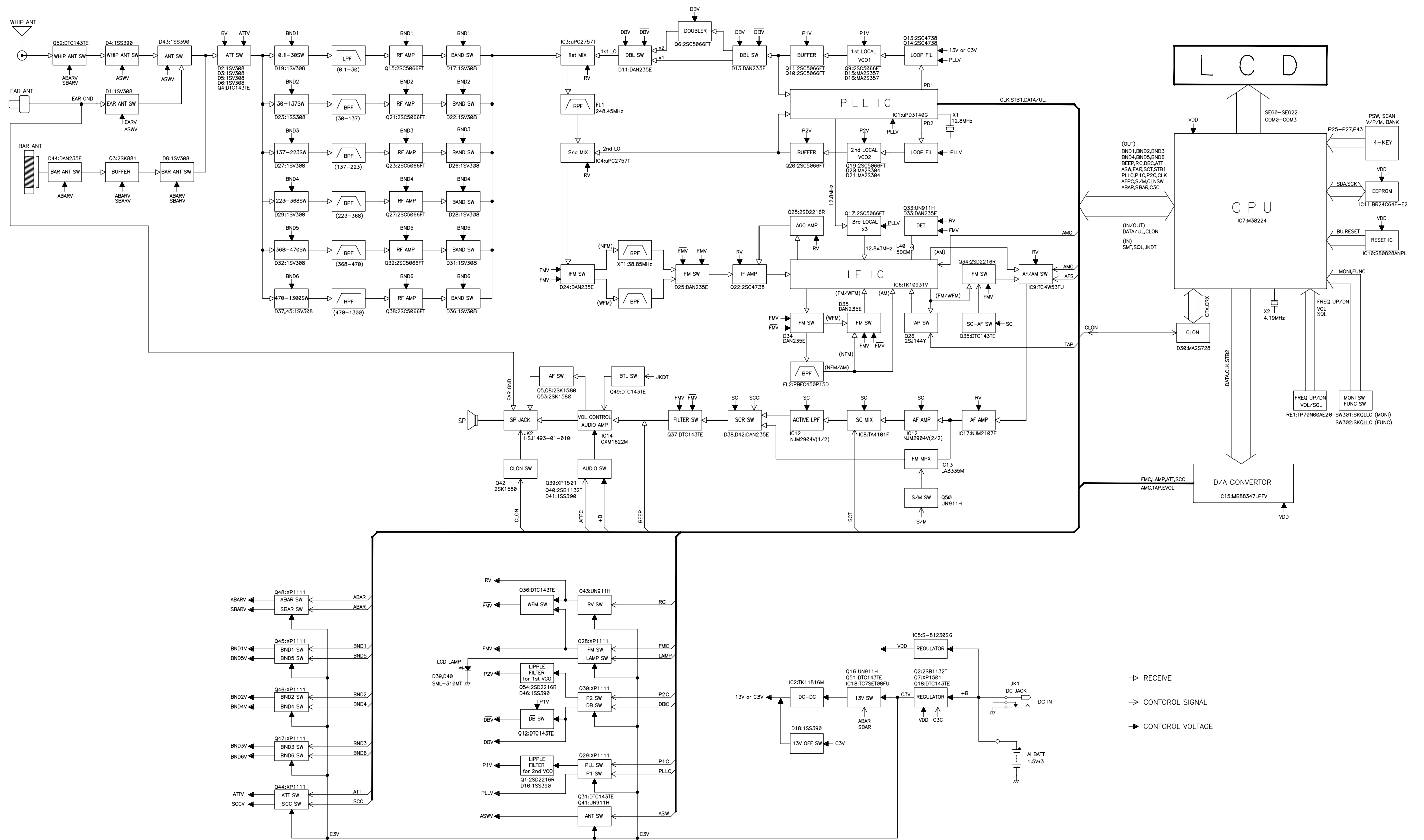

- ⇨ RECEIVE
- ⇒ CONTROL SIGNAL
- ➔ CONTROL VOLTAGE

# ALINCO, INC.

**Head Office :** Shin-Dai Building 9th Floor  
2-6, 1-Chome, Dojimahama, Kita-ku, Osaka 530-0004, Japan  
Phone: +81-6-4797-2136 Fax: +81-6-4797-2157  
E-mail:[export@alinco.co.jp](mailto:export@alinco.co.jp)

Dealer/Distributor